

S type steel agricultural chain attachments

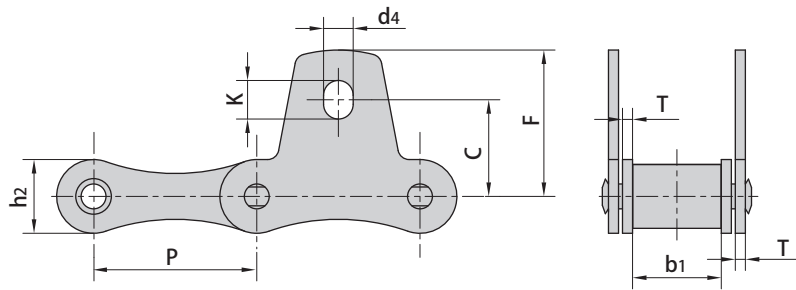

Donghua Chain No.	P	b1	h2	T	C	F	d4	K
	mm	mm	mm	mm	mm	mm	mm	mm
S32SK1	29.21	15.88	13.2	1.8	17.3	26.20	5.3	6.9
S42SK1	34.93	19.05	19.8	2.8	23.6	34.30	8.3	11.5
S45SK1	41.40	22.23	17.3	2.8	19.8	30.20	8.3	11.5
S52SK1	38.10	22.23	17.3	2.8	22.1	31.80	8.3	9.9
S55SK1	41.40	22.23	17.3	2.8	19.8	30.20	8.3	11.5
S62SK1	41.91	26.20	17.3	2.5	24.6	38.60	8.3	14.7
S77SK1	58.34	22.23	26.2	4.0	36.3	50.00	8.3	11.5
S88SK1	66.27	28.58	26.2	4.0	43.7	55.60	8.3	9.9
S32SK1F1	29.21	15.88	13.2	1.8	16.7	25.68	6.5	8.1
S55RHSK1	41.40	22.23	22.4	4.0	19.8	30.20	8.3	11.5

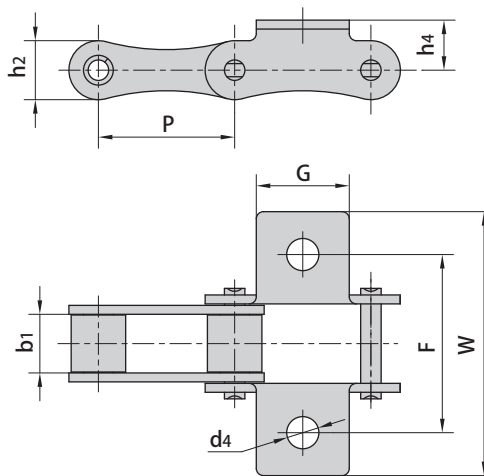

Donghua Chain No.	P	b1	G	F	W	h4	d4	h2
	mm	mm	mm	mm	mm	mm	mm	mm
S52LK1	38.10	16.40	26.0	50.0	74.0	14.0	9.0	16.5
S55VK1	41.40	22.23	30.0	58.0	76.0	16.0	9.0	20.0
S42F2K1F1	34.93	19.05	45.0	54.8	75.2	14.0	8.3	19.8
S52LF1K1	38.10	16.00	26.0	50.0	74.0	16.0	9.0	16.5

S type steel agricultural chain attachments

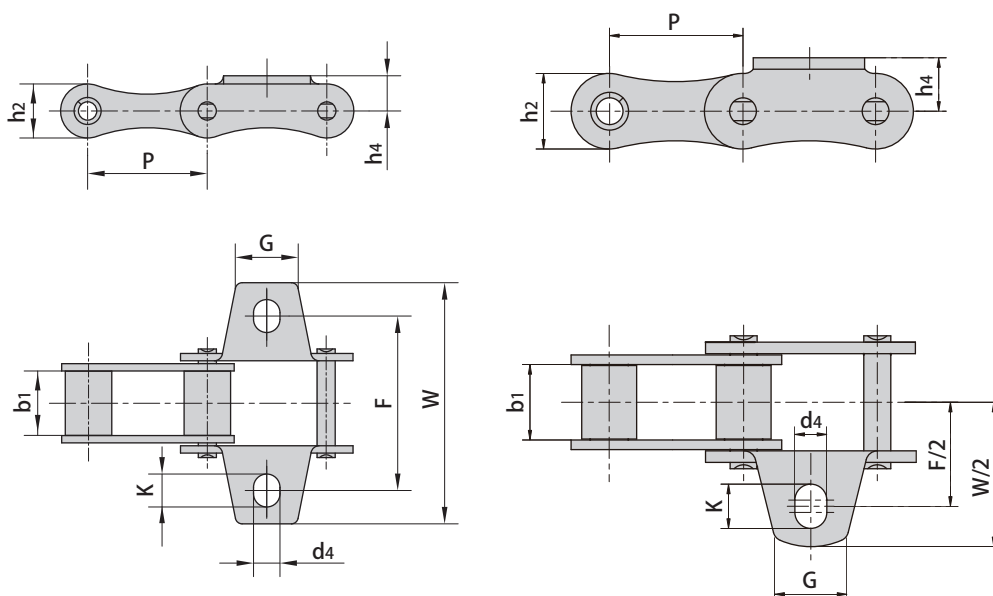

Donghua Chain No.	P	b1	G	F	W	h4	d4	K	h2
	mm	mm	mm	mm	mm	mm	mm	mm	mm
S32K1	29.21	15.88	15.0	42.9	61.0	8.6	5.3	6.9	13.2
S32K1F1	29.21	15.88	15.0	42.9	61.0	8.6	6.5	8.1	13.2
S42K1	34.93	19.05	17.5	54.0	74.9	14.0	8.3	11.5	19.8
S45K1	41.40	22.23	22.0	54.0	75.0	11.4	8.5	11.7	17.3
S51K1	38.10	16.00	19.0	49.8	71.5	11.4	8.3	9.9	17.3
S52K1	38.10	22.23	19.0	58.8	78.0	11.4	8.3	9.9	17.3
S52K1F1	38.10	22.23	19.0	58.8	78.0	11.4	6.6	8.2	17.3
S55K1	41.40	22.23	22.0	54.0	75.0	11.4	8.5	11.7	17.3
S55K1F1	41.40	22.23	22.0	54.0	75.0	11.4	6.5	9.5	17.3
S55HK1	41.40	22.23	34.0	52.7	82.0	13.4	8.4	11.4	20.4
S62K1	41.91	26.20	22.0	66.8	95.4	11.4	8.3	14.7	17.3
S62A2K1	41.91	26.20	22.0	66.7	95.5	12.6	8.3	14.7	17.3
S62F2K1	41.91	26.20	22.0	66.8	95.4	11.4	6.5	13.0	17.3
S62F5A2K1	41.91	26.20	22.0	66.7	95.5	12.6	8.3	14.7	16.7
S77K1	58.34	22.23	25.0	76.2	102.0	20.8	8.3	11.5	26.2
S88K1	66.27	28.58	22.0	97.0	119.4	20.8	8.3	9.9	26.2
S51HF1K1	38.10	16.00	34.0	52.4	84.5	13.0	8.3	9.9	21.0
S88F2K1	66.27	28.58	22.0	97.0	119.4	20.8	8.3	9.9	26.2
S42A1F2	34.93	19.05	23.6	54.0	75.0	14.0	6.9	10.1	19.8
S42F2A1	34.93	19.05	17.5	54.0	75.0	14.0	8.3	11.5	19.8
S88F3K1	66.27	28.58	30.0	97.7	120.0	20.5	8.3	9.9	26.2
S62F12K1	41.91	25.40	22.0	65.9	94.7	12.6	8.3	14.7	16.7

S type steel agricultural chain attachments

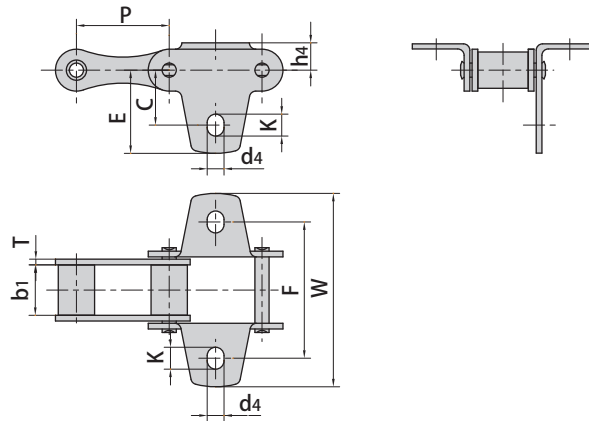

Donghua Chain No.	P	b1	T	C	E	F	W	d4	K	h4
	mm	mm	mm	mm	mm	mm	mm	mm	mm	mm
S32F1	41.4	29.21	1.8	17.3	26.2	42.9	60	5.3	6.9	8.6

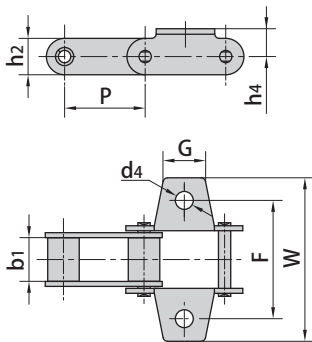

Donghua Chain No.	P	b1	G	F	W	h4	d4	h2
	mm	mm	mm	mm	mm	mm	mm	mm
S52F1	38.4	18.50	23.0	57.5	80.0	16.0	8.7	17.5
S55VK1F2	41.4	22.23	22.0	54.0	72.0	15.0	8.7	20.0
S52F13K1	38.1	19.00	17.0	57.0	81.0	15.4	9.1	17.3

Donghua Chain No.	P	b1	G	F	W	h4	d4	h2
	mm	mm	mm	mm	mm	mm	mm	mm
S52F2	38.4	18.50	39.0	57.0	80.0	16.0	10.5	17.5
S52F7	38.4	19.05	39.0	58.4	82.4	14.5	10.5	20.5
S52F12	38.1	19.05	39.0	57.5	79.5	14.5	10.0	14.5

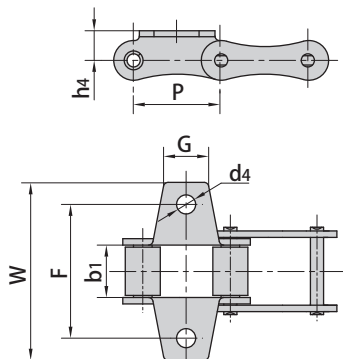
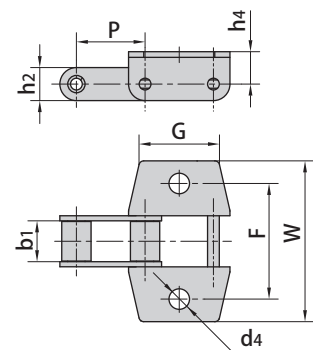

Donghua Chain No.	P	b1	G	F	W	h4	d4
	mm	mm	mm	mm	mm	mm	mm
S52F6	38.10	22.23	19.0	51.2	71.7	16.5	8.3
S5VK1F2	41.40	22.23	20.0	71.0	93.8	16.0	8.4
S5VK1F3	41.40	22.23	22.0	54.0	72.0	15.0	8.7
S62A1F1	41.91	26.20	26.0	63.0	92.0	11.4	7.0

S type steel agricultural chain attachments

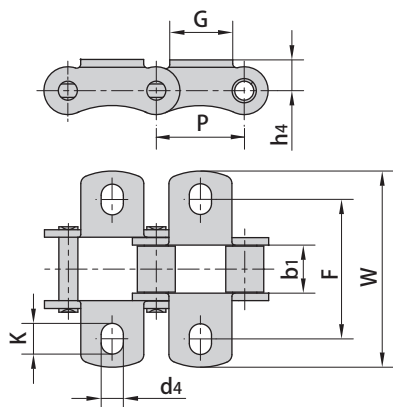

Donghua Chain No.	P	b ₁	G	F	W	h ₄	d ₄	K
	mm	mm	mm	mm	mm	mm	mm	mm
S55RK1	41.4	22.23	25.0	63.6	90.4	15.5	8.6	12.0
S55RHK1	41.4	22.23	25.0	63.6	90.4	15.5	8.6	12.0
CA645K1	41.4	22.23	25.0	58.0	83.0	18.5	8.5	12.0
S55RHF2K1	41.4	22.23	24.0	63.4	84.6	16.0	8.5	12.0

Donghua Chain No.	P	b ₁	G	F	W	h ₄	d ₄	h ₂
	mm	mm	mm	mm	mm	mm	mm	mm
S32K1F2	29.21	15.88	15.0	42.9	61.0	8.6	5.3	13.2
S52K1F2	38.10	22.23	22.0	58.7	76.5	11.4	8.5	17.3
S45K1F1	41.40	22.23	22.0	51.0	75.0	11.4	7.2	17.3
S5VK1F1	41.40	22.23	22.0	56.0	75.0	16.0	10.0	20.0
S55F5	41.40	22.23	22.0	56.0	75.0	11.4	10.0	17.3
S77K1F1	58.34	22.23	26.0	76.2	103.8	20.8	10.5	26.2
S55K1F2	41.40	22.23	22.0	55.0	75.0	11.4	8.5	17.3

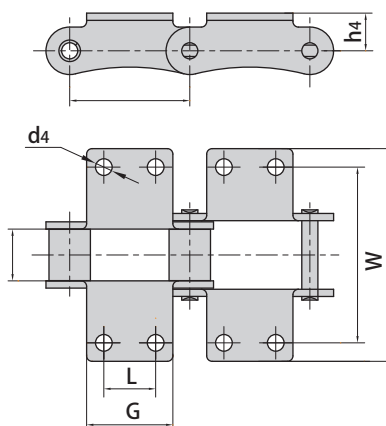
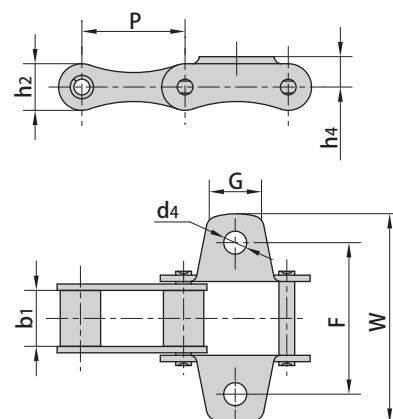

Donghua Chain No.	P	b ₁	L	G	F	W	h ₄	d ₄
	mm	mm	mm	mm	mm	mm	mm	mm
S88K2F1	66.27	28.58	28.6	47.6	97.0	117.4	20.8	9.2
S62K2F1	41.91	26.20	19.1	35.0	66.8	95.4	11.4	8.3

S type steel agricultural chain attachments

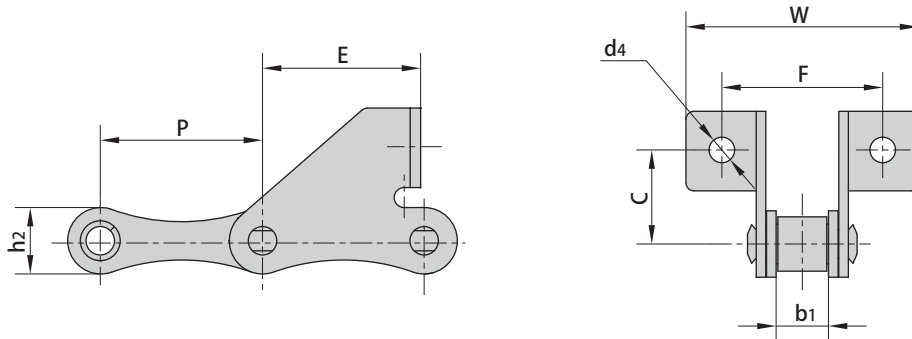

Donghua Chain No.	P	b1	C	E	F	W	d4	h2
	mm	mm	mm	mm	mm	mm	mm	mm
S32SD	29.21	15.88	20.00	19.2	58.0	78.0	6.4	13.2
S51SDF1	38.10	16.00	19.65	20.0	56.0	82.0	6.4	17.3
S52SDF1	38.10	15.80	19.56	20.0	56.0	82.0	6.4	17.3
S52SDF2	38.10	22.20	20.20	37.2	57.6	86.2	6.5	16.4
S52SD	38.10	22.23	20.00	19.2	62.0	88.5	6.4	17.3
S52F4	38.10	15.80	20.60	37.0	53.8	69.5	6.4	16.7
S52F8	38.10	22.23	20.60	37.0	60.7	76.4	6.4	17.3
S52F9	38.10	18.50	20.00	18.5	54.5	71.0	6.5	16.5
S52LSD	38.10	16.40	20.00	17.5	54.5	71.0	6.5	16.5
S52LF1SD	38.10	22.02	20.00	17.5	54.5	71.0	6.5	16.5
S52LF2SD	38.10	16.00	20.00	19.0	54.6	76.6	6.5	17.0
S52F12SD	38.10	13.00	20.00	30.0	47.5	83.4	6.4	17.3
S52LVSD	38.10	17.80	20.00	19.2	62.0	85.5	6.4	16.7
S45F1	41.40	22.23	21.00	25.0	62.4	83.4	8.5	17.3
S45SDF2	41.40	22.23	21.00	28.5	62.4	83.4	8.5	17.3
S45W-F1	41.40	22.23	20.00	37.0	58.0	87.0	6.6	17.3
S45W-F4	41.40	22.23	20.50	33.2	58.0	85.6	6.6	17.3
S45SD	41.40	22.23	17.00	28.6	58.0	81.2	8.5	17.3
S55F2	41.40	22.23	20.00	37.0	58.0	87.0	6.4	17.3
S55F3	41.40	22.23	20.50	33.2	58.0	85.6	6.6	17.3
S55F4	41.40	22.23	20.00	37.0	58.0	87.0	6.6	17.3
S55F6	41.40	22.23	20.00	30.0	58.0	87.0	6.4	17.3
S55F7	41.40	22.23	20.50	33.2	62.0	85.6	6.6	17.3
S55RSDF1	41.40	22.23	20.50	33.2	62.0	85.6	6.6	22.4
S5VSDF1	41.40	22.23	20.50	33.2	62.0	85.6	6.6	20.0
S5VSDF2	41.40	22.23	20.50	33.2	62.0	85.6	8.3	20.0
S5VSDF4	41.40	22.23	23.40	28.5	57.5	83.4	6.5	20.0
S55SDF2	41.40	22.23	20.00	33.4	58.0	86.0	6.6	17.3
S55SDF4	41.40	22.23	25.00	36.0	58.0	85.0	6.5	17.3
S62SD	41.91	26.20	20.00	32.6	61.4	92.0	6.4	17.3

S type steel agricultural chain attachments

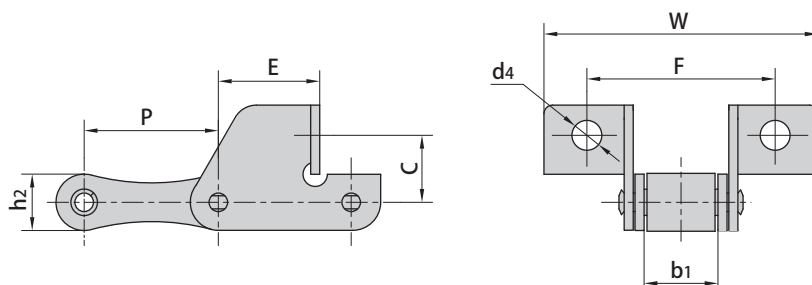

Donghua Chain No.	P	b ₁	C	E	F	W	d ₄	h ₂
	mm	mm	mm	mm	mm	mm	mm	mm
S45V	41.4	22.23	21.0	28.5	62.4	83.4	8.8	17.3
S45SDF1	41.4	22.23	17.5	31.9	62.0	91.0	8.5	17.3
S55V	41.4	22.23	21.0	28.5	57.5	83.4	6.5	17.3
S55SDF1	41.4	22.23	20.0	31.9	58.0	89.2	6.5	17.3
S45SDF3	41.4	22.23	16.5	31.9	62.0	91.0	8.5	17.3
S55HSDF3	41.4	22.23	20.6	32.5	64.0	91.0	8.5	20.4
S55F12SD	41.4	22.23	20.0	30.0	61.6	94.7	6.5	17.3

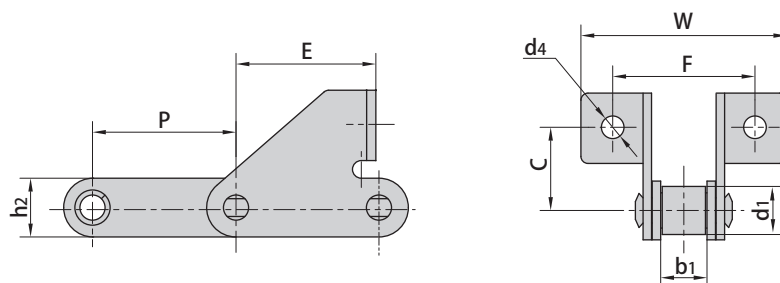

Donghua Chain No.	P	d ₁	b ₁	C	E	F	W	d ₄	h ₂
	mm	mm	mm	mm	mm	mm	mm	mm	mm
S52F11SD	38.1	16.00	17.50	21.0	23.0	55.0	75.0	8.3	20.0
S52F3	38.4	15.88	18.50	24.0	37.4	52.0	73.0	8.7	17.5
C45F1SD	41.4	15.24	22.23	19.7	41.7	58.0	90.0	6.6	17.3

S type steel agricultural chain attachments

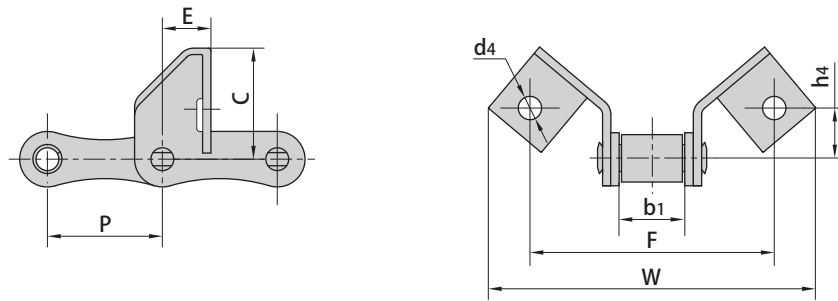

Donghua Chain No.	P mm	b1 mm	C mm	E mm	F mm	W mm	h4 mm	d4 mm
55VSE	41.4	22.23	41.0	17.5	88	118	18.44	8.4
55VSEL	41.4	22.23	41.0	31.3	88	118	18.44	8.4
55VSEF1	41.4	22.23	40.0	25.0	88	118	18.00	8.4
CA645SE	41.4	22.23	40.0	17.5	88	118	18.00	8.4

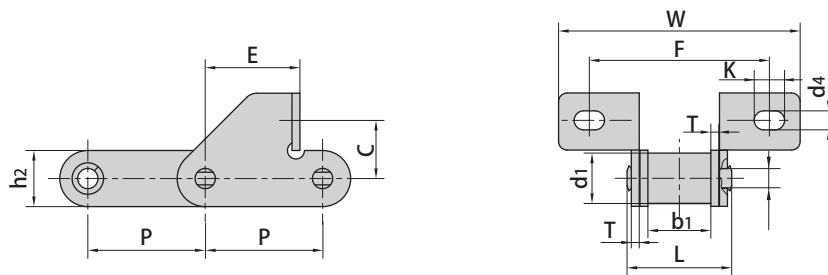

Donghua Chain No.	P mm	C mm	E mm	F mm	W mm	d4 mm	K mm
S55F9SD	41.4	20.5	33.4	62.0	85.4	6.7	10.7
S55HSDF2	41.4	20.6	32.5	64.0	91.0	7.5	10.7
55VF1SDF1	41.4	18.8	26.7	65.5	90.0	8.5	10.0

Donghua ChainNo.	Pitch	Roller diameter	Width between inner plates	Pin diameter	Pin length	Plate dimension		Ultimate tensile strength	Weight per meter
	P	d1 max	b1 min	d2 max	L max	h2 max	T	Q min	q
	mm	mm	mm	mm	mm	mm	mm	kN/lbf	kg/m
S55F9SD	41.4	17.78	22.20	7.14	37.0	19.8	2.8	35.0/7873	2.7
S55HSDF2	41.4	15.20	22.23	8.28	39.5	20.4	3.0	45.0/10116	2.6
55VF1SDF1	41.4	17.90	22.23	8.22	39.3	21.4	3.0	45.0/10116	2.9

S type steel agricultural chain attachments

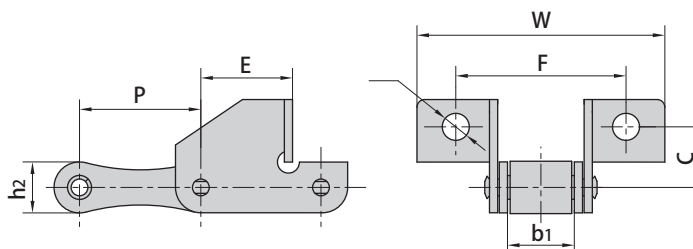

Donghua Chain No.	P	b ₁	C	E	F	W	d ₄	h ₂
	mm	mm	mm	mm	mm	mm	mm	mm
S55F1	41.4	22.23	19.0	31.9	62.0	89.2	8.3	17.3
S55RSD	41.4	22.23	19.0	31.9	62.0	89.2	8.3	22.4
S55SDF3	41.4	22.23	17.2	31.9	62.0	92.0	8.3	17.3
S55HSDF1	41.4	22.23	20.6	41.8	64.0	91.0	8.4	20.4
S55RHSD1	41.4	22.23	25.4	31.5	71.0	101.0	8.5	22.4
S55F10SD	41.4	22.23	20.0	30.0	57.0	90.1	6.5	17.3
CA2060F1SD	38.1	12.70	21.0	29.7	47.6	82.5	6.4	17.3

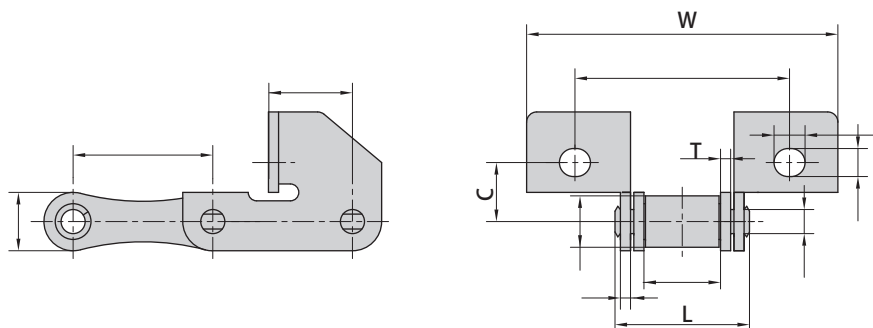

Donghua Chain No.	P	C	E	F	W	d ₄	K
	mm	mm	mm	mm	mm	mm	mm
S45HF1	41.4	17.50	24.9	63.4	92.0	8.3	9.2
S55HSD	41.4	20.60	32.5	64.0	91.0	7.5	10.7
S45HSDF1	41.4	17.50	31.1	63.5	84.0	8.3	9.2

Donghua Chain No.	Pitch	Roller diameter	Width between inner plates	Pin diameter	Pin length	Plate dimension		Ultimate tensile strength	Weight per meter
	P	d ₁ max	b ₁ min	d ₂ max	L max	h ₂ max	T	Q min	q
	mm	mm	mm	mm	mm	mm	mm	kN/lbf	kg/m
S45HF1	41.4	15.24	22.23	7.14	39.5	17.3	3.0	36.75/8267	2.0
S55HSD	41.4	17.78	22.23	8.28	39.5	20.4	3.0	45.00/10122	2.9
S45HSDF1	41.4	15.24	22.23	7.14	39.5	17.3	3.0	36.75/8267	2.6

S type steel agricultural chain attachments

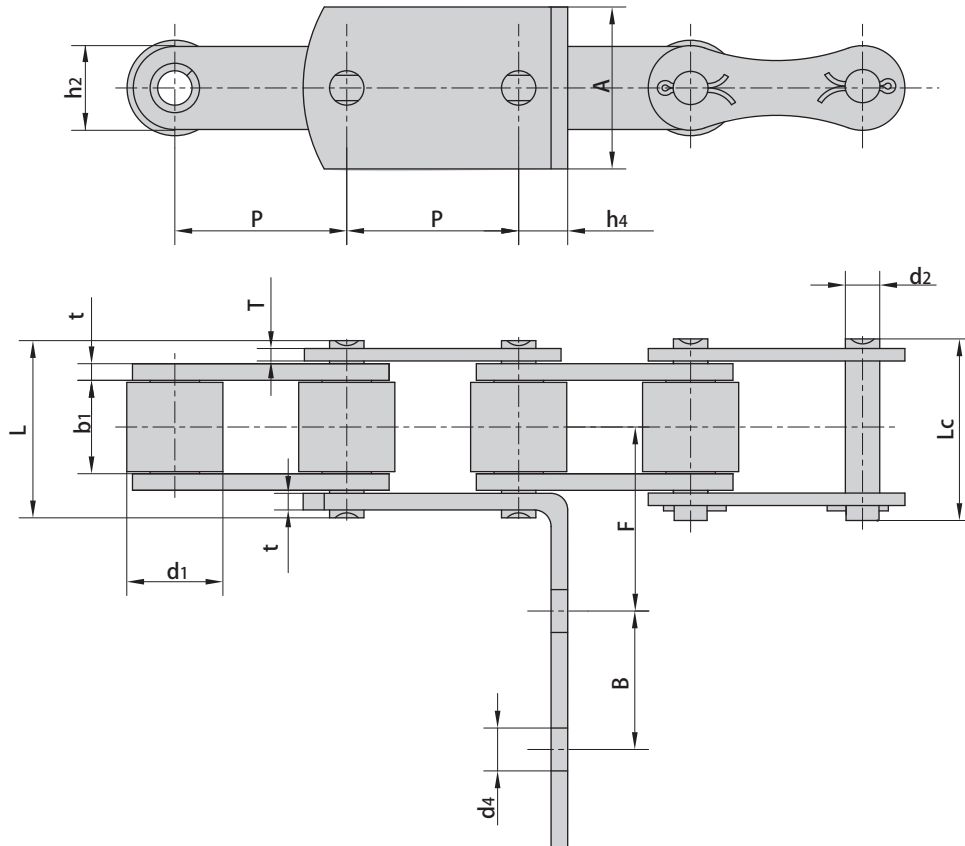

Donghua Chain No.	P	A	B	F	h4	d4
	mm	mm	mm	mm	mm	mm
S55HF2	41.4	39.0	50	61.0	11.8	8.3
S55HF1	41.4	30.0	30	32.0	13.5	6.5

Donghua Chain No.	Pitch	Roller diameter	Width between inner plates	Pin diameter	Pin length		Plate dimension		Ultimate tensile strength	Weight per meter
	P	d1 max	b1 min	d2 max	L max	Lc max	h2 max	t/T	Q min	q
	mm	mm	mm	mm	mm	mm	mm	mm	kN/lbf	kg/m
S55HF2	41.4	23.00	22.23	8.28	42.0	45.5	20.0	4.0/3.0	47.5/10685	4.27
S55HF1	41.4	17.78	22.23	8.28	39.5	42.8	20.4	3.0	45/10122	2.90

S type steel agricultural chain attachments

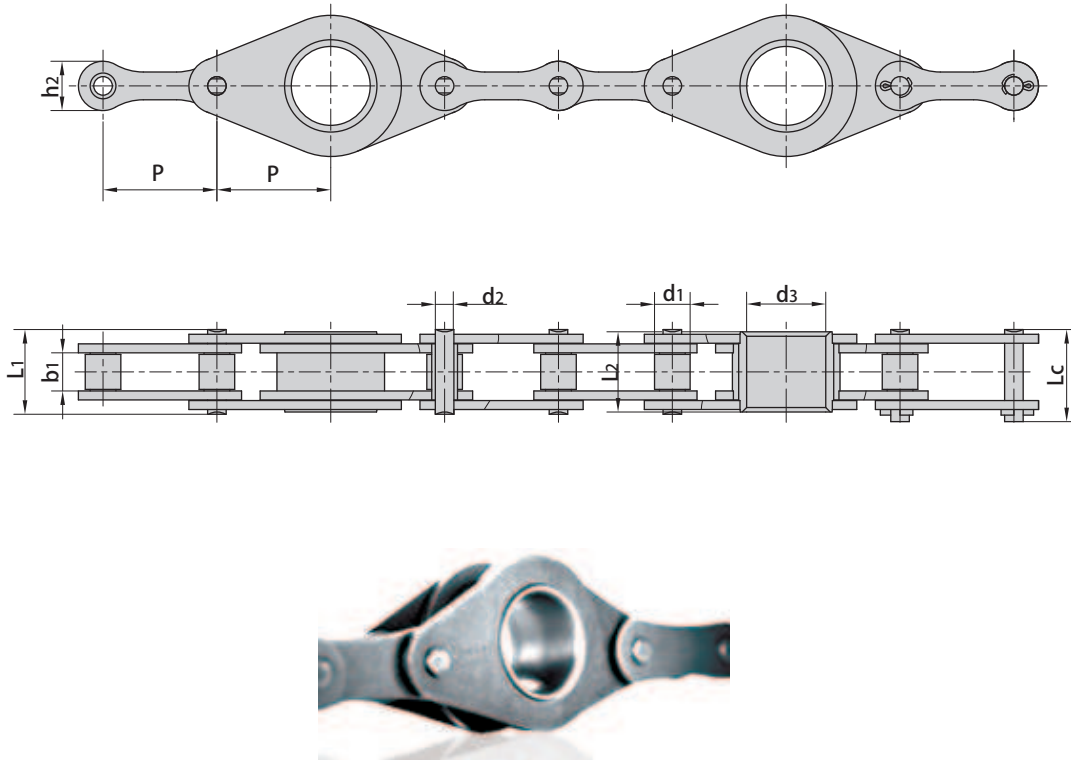

Donghua Chain No.	Pitch	Roller diameter	Width between inner plates	Pin diameter	Hollow pin inner diameter	Pin length			Inner plate depth	Ultimate tensile strength	Average tensile strength
	P	d1 max	b1 min	d2 max	d3 min	L1 max	L2 max	Lc max	h2 max	Q min	Q0
	mm	mm	mm	mm	mm	mm	mm	mm	mm	kN/lbf	kN
216BF1	50.8	15.88	17.02	8.28	35.3	37.8	35.8	41.3	22.0	60.0/13636	70.8
CA650F3	50.8	19.05	19.05	9.53	35.3	40.4	37.8	44.7	25.0	90.0/20454	99.0

S type steel agricultural chain attachments

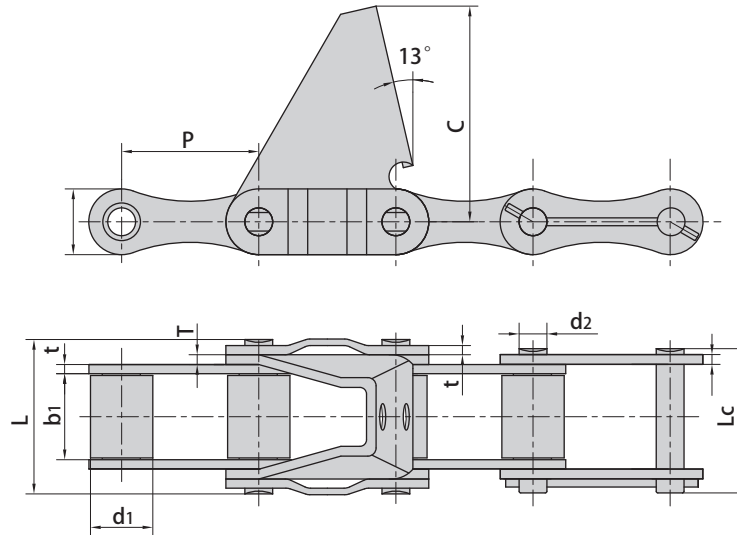

Donghua Chain No.	Pitch	Roller diameter	Width between inner plates	Pin diameter	Pin length		Plate dimension			Ultimate tensile strength	Average tensile strength
	P	d1 max	b1 min	d2 max	L max	Lc max	h2 max	t/T	C	Q min	Q0
	mm	mm	mm	mm	mm	mm	mm	mm	mm	kN/lbf	kN
S62R-C6E	41.91	19.05	25.8	8.5	47.8	44.6	20.1	2.8/3.0	66.0	42.0/9448	43.7

Donghua Chain No.	P	b1	C	α	L	T	h2
	mm	mm	mm		mm	mm	mm
S62F1	41.91	25.4	60.0	50°	41.9	3.0	20.0

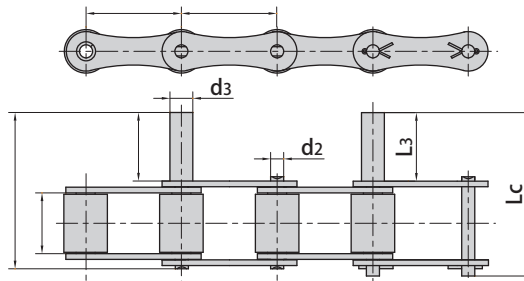
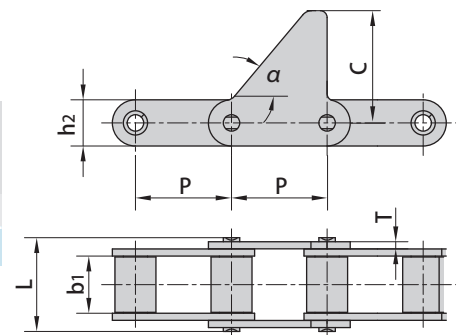

Donghua Chain No.	P	b1	d2	d3	L3	L	Lc
	mm	mm	mm	mm	mm	mm	mm
S62-D4	41.91	26.2	5.72	10.00	35	73.8	76.5
S42-D1F1	34.93	19.05	7.00	9.95	25	58.0	61.0
S42-D2	34.93	19.05	7.00	10.00	30	63.0	65.7
S62-D3F1	41.91	26.20	5.72	5.72	18	56.8	59.5