

Short pitch conveyor chains with top rollers

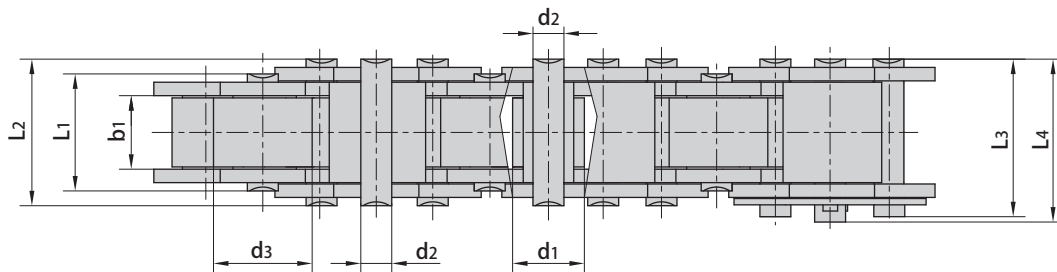
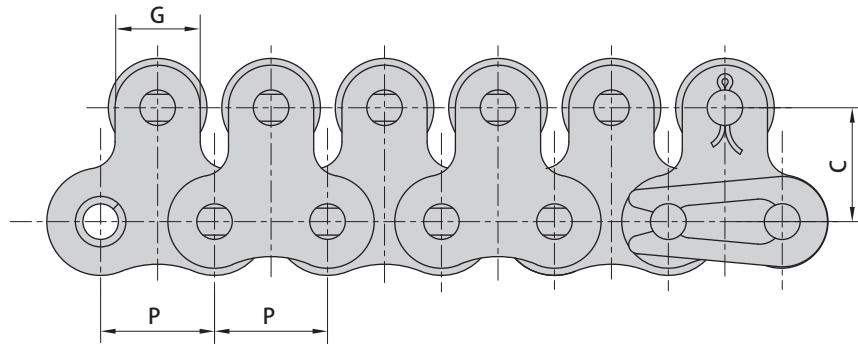

Donghua Chain No.	Pitch	Roller diameter		Width between inner plates		Pin length				Attachment dimension		Ultimate tensile strength	Weight per meter
	P mm	d1 max mm	d3 max mm	b1 min mm	d2 max mm	L1 max mm	L2 max mm	L3 max mm	L4 max mm	G mm	C mm	Q _{min} kN/lbf	q kg/m
40-1-1LTR	12.700	7.95	11.0	7.85	3.96	13.5	16.6	17.8	18.8	9.5	12.7	14.1/3250	1.44
50-1-1LTR	15.875	10.16	15.0	9.40	5.08	16.5	20.7	22.2	23.3	12.7	15.9	22.2/5405	2.30
60-1-1LTR	19.050	11.91	18.0	12.57	5.94	21.0	25.9	27.7	28.3	15.9	18.3	31.8/7227	3.40
80-1-1LTR	25.400	15.88	24.0	15.75	7.92	26.2	32.7	35.0	36.5	19.1	24.6	56.7/12886	5.90
100-1-1LTR	31.750	19.05	30.0	18.90	9.53	32.3	40.4	44.7	44.7	25.4	31.8	88.5/20114	8.90