

Rubber gloves carrier chains

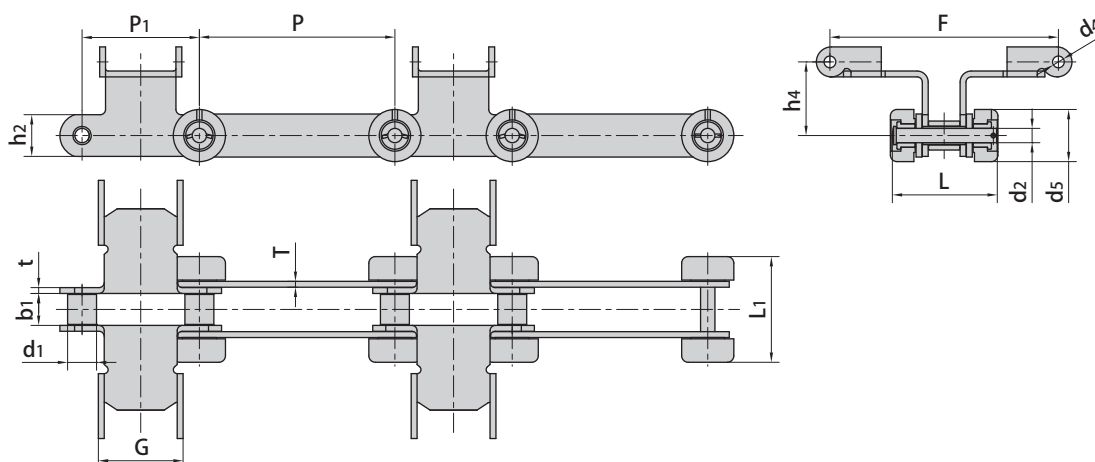

Donghua Chain No.	Pitch		Roller diameter	Width between inner plates	Pin diameter	Pin length	Plate depth	Plate thickness	Ultimate tensile strength	Weight per meter
	P	P1	d1 max	b1 min	d2 max	L max	h2 max	t/T max	Q min	q
	mm	mm	mm	mm	mm	mm	mm	mm	kN/lbf	kg/m
P100F13	100.0	-	22.23	22.5	10.8	76.5	32.0	6.0/4.5	60/13488	9.32
P100F139	100.0	-	22.00	24.0	12.0	75.0	32.0	6.0	60/13488	11.87
P150/90	150.0	90.0	22.20	24.3	10.8	81.5	32.0	4.5	60/13488	8.10

Donghua Chain No.	G	L1	F	h4	d4	d5
	mm	mm	mm	mm	mm	mm
P100F13	74.6	79.5	175.0	56.5	9.2	40.0
P100F139	74.6	83.5	175.0	56.5	9.1	40.0
P150/90	65.0	82.0	175.0	57.0	9.2	40.0

Sewage disposal chains

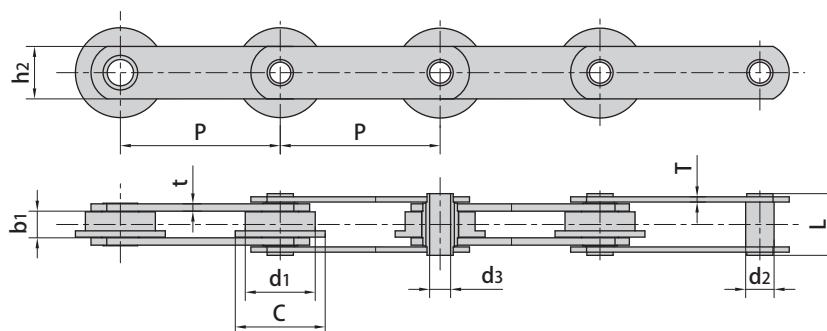

Donghua Chain No.	Pitch	Width between inner plates	Roller diameter	Pin diameter	Pin length	Plate depth	Plate thickness	Ultimate tensile strength	Average tensile strength	Weight per meter			
	P	b1 min	d1 max	C max	d2 max	d3 min	L max	h2 max	T max	t max	Q min	Q0	q
	mm	mm	mm	mm	mm	mm	mm	mm	mm	mm	kN/lbf	kN	kg/m
W152	152.4	25.40	66.7	85.7	27.1	20.0	58.8	50.0	5.0	7.0	110.0/25000	122.1	10.78