

Escalator step chains

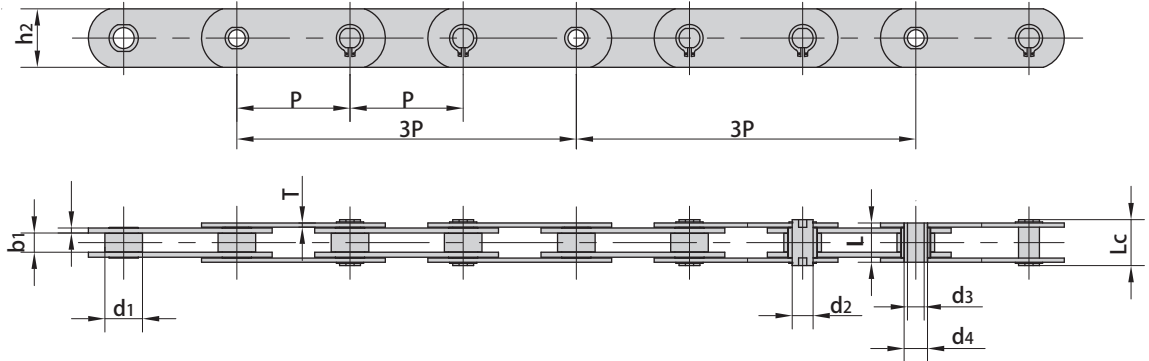

Donghua Chain No.	Pitch	Roller diameter	Width between inner plates	Pin diameter	(Hollow) Pin diameter	Pin length			Plate dimension		Ultimate tensile strength	Average tensile strength	Weight per step
	P mm	d1 max mm	b1 min mm	d2 max mm	d3 min mm	d4 max mm	L max mm	Lc max mm	h2 mm	t/T max mm	Q min kN/lbf	Q0 kN	q kg
PT135HP	135.46	45.0	23.0	25.0	20.0	28.0	47.1	55.1	70	6.0/5.0	250/56202	275.0	4.5

Moving walkway escalator chains

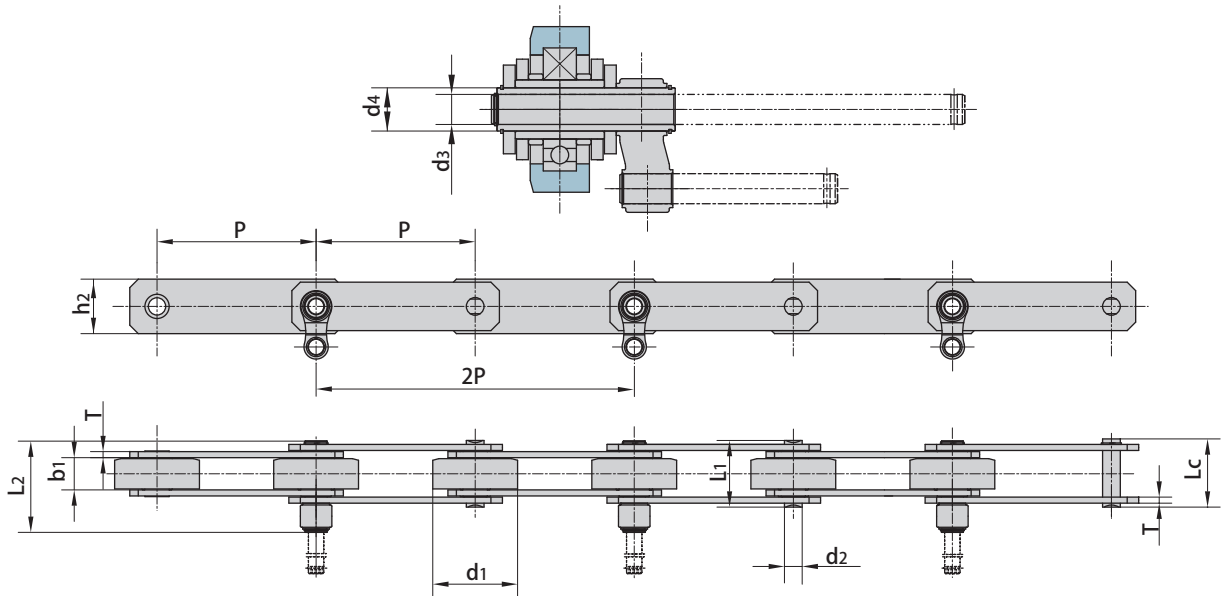

Donghua Chain No.	Pitch	Roller diameter	Width between inner plates	Pin diameter	(Hollow) Pin diameter	Pin length			Plate dimension		Ultimate tensile strength	Average tensile strength	Weight per step	
	P	d1 max mm	b1 min mm	d2 max mm	d3 min mm	d4 max mm	L1 max mm	L2 max mm	Lc max mm	h2 mm	T mm	Q min kN/lbf	Q0 kN	q kg
	mm	mm	mm	mm	mm	mm	mm	mm	mm	mm	mm	kN/lbf	kN	kg
PT131HP	131.33	70.0	27.0	14.63	12.7	18.26	55.0	75.3	56.0	40.0	5.0	150.0/33721	165.0	7.53
PT135HPF1	135.46	76.2	24.0	12.70	14.1	20.00	51.3	68.1	-	40.0	5.0	127.0/28550	140.0	-

Moving walkway escalator chains

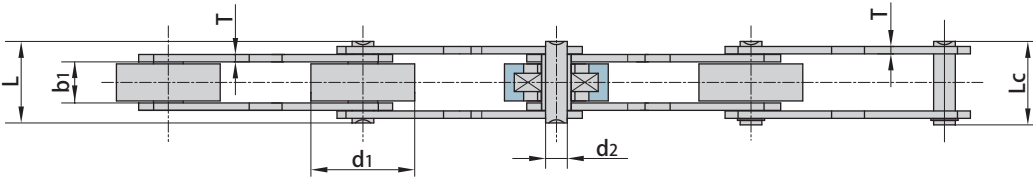
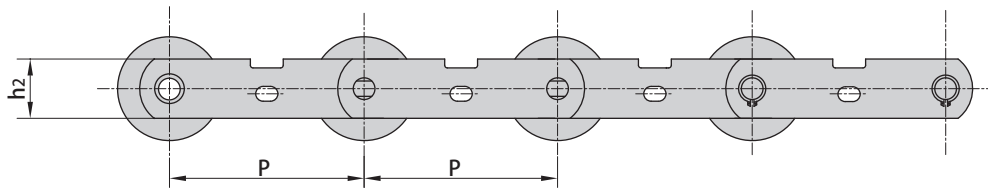
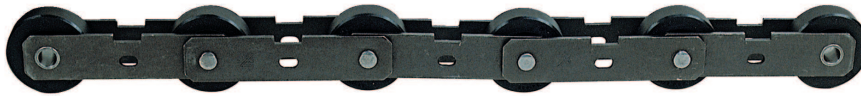

Donghua Chain No.	Pitch	Roller diameter	Width between inner plates	Pin diameter	Pin length		Inner plate depth	Plate thickness	Ultimate tensile strength	Average tensile strength	Weight per meter
	P	d1 max	b1 min	d2 max	L max	Lc max	h2	T max	Q min	Q0	q
	mm	mm	mm	mm	mm	mm	mm	mm	kN/lbf	kN	kg/m
PT131	131.33	70.00	27.00	14.63	55.0	56.0	40.0	5.0	180.0/40465	198.0	5.97
PT133	133.33	70.00	27.00	14.63	55.0	56.0	40.0	5.0	180.0/40465	198.0	5.75

