

## Hollow pin conveyor chains (MC series)

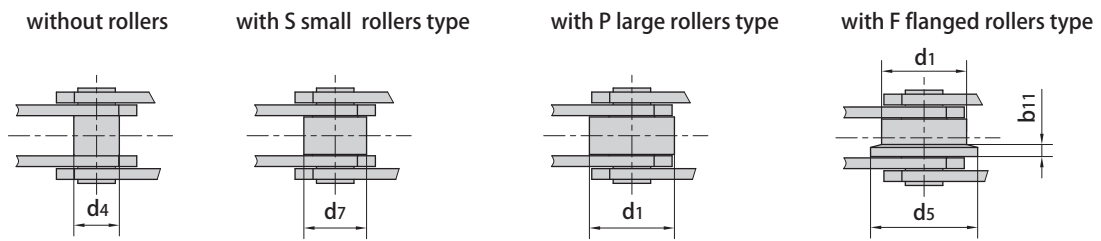
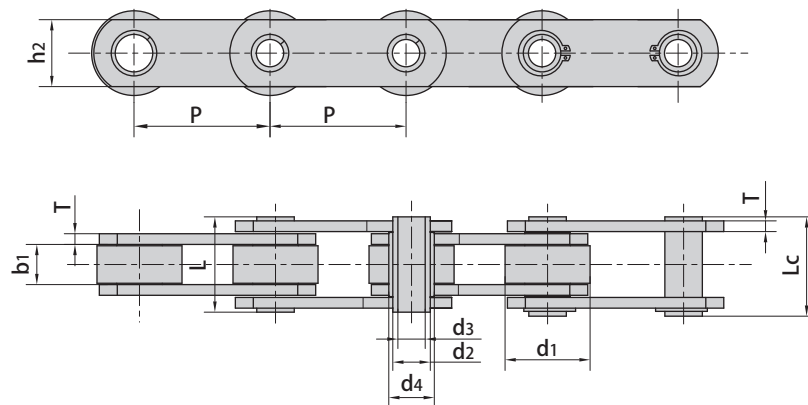

DIN Chain No.	Pitch						Roller dimension				Bush diameter	Plate depth
	P						d1 max	d7 max	d5 max	b11	d4 max	h2 max
	mm						mm	mm	mm	mm	mm	mm
MC28	63.0	80.0	100.0	125.0	160.0	-	36.0	25.0	45.0	4.5	17.5	25.0
MC56	80.0	100.0	125.0	160.0	200.0	250.0	50.0	30.0	60.0	5.0	21.0	35.0
MC112	100.0	125.0	160.0	200.0	250.0	315.0	70.0	42.0	85.0	7.0	29.0	50.0
MC224	160.0	200.0	250.0	315.0	400.0	500.0	100.0	60.0	120.0	10.0	41.0	70.0

DIN Chain No.	Width between inner plates	Pin diameter		Pin length		Plate thickness	Breaking load	
	b1 min	d2 max	d3 min	L max	Lc max	T max	Q min	*Q min
	mm	mm	mm	mm	mm	mm	kN/lbf	kN/lbf
MC28	20.0	13.0	8.2	36.0	38.5	3.5	28.0/6364	40.0/9091
MC56	24.0	15.5	10.2	45.0	47.5	4.0	56.0/12727	90.0/20454
MC112	32.0	22.0	14.3	62.5	64.3	6.0	112.0/25454	180.0/40908
MC224	43.0	31.0	20.3	83.0	85.5	8.0	224.0/50909	350.0/79544

\*Q denotes the ultimate tensile strength after hardened