

## Top plate conveyor chains

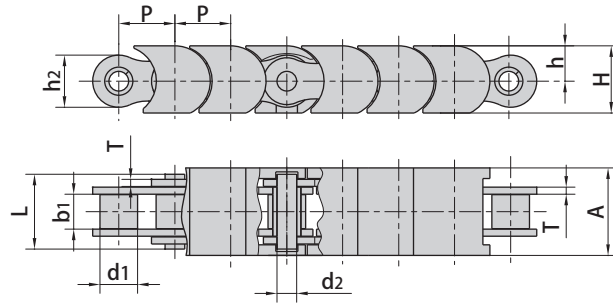

Donghua Chain No.	Pitch	Roller diameter	Width between inner plates	Pin diameter	Pin length	Plate dimension		Plastic attachment dimension			Ultimate tensile strength
	p	d1 max	b1 min	d2 max	L max	h2 max	T max	A	h	H	Q min
	mm	mm	mm	mm	mm	mm	mm	mm	mm	mm	kN/lbf
08B-TP	12.700	8.51	7.75	4.45	16.7	11.8	1.60	19.8	8.0	15.2	18/4091
10B-TP	15.875	10.16	9.65	5.08	19.5	14.7	1.70	24.8	9.5	17.5	22.4/5091
12B-TP	19.050	12.07	11.68	5.72	22.5	16.0	1.85	29.8	11.0	19.8	29/6591

## Double flex chains

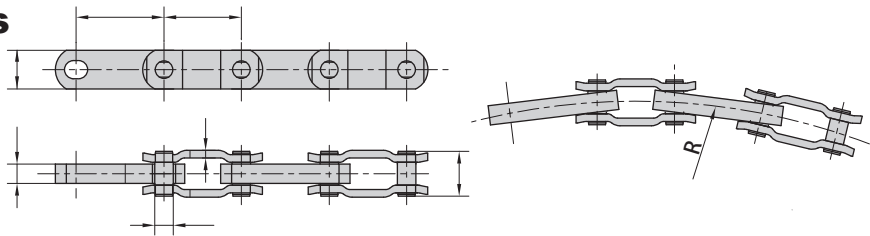

Donghua Chain No.	Pitch	Pitch	Thickness of inner plates	Pin diameter	Pin length	Plate dimension		Side bow radius	Ultimate tensile strength	Average tensile strength	Weight per meter
	P1	P2	T	d2 max	L max	H max	t	R min	Q min	Q0	q
	mm	mm	mm	mm	mm	mm	mm	mm	kN/lbf	kN	kg/m
3500	63.5	76.2	15.9	14.27	37.0	32.0	6.3	508.0	160.0/36363	196.0	5.14

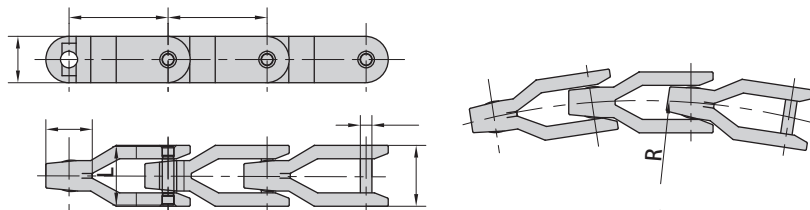

Donghua Chain No.	Pitch	Pin diameter	Pin length	Plate dimension			Side bow radius	Ultimate tensile strength	Weight per meter
	P	d2 max	L	H max	W max	d1	R min	Q min	q
	mm	mm	mm	mm	mm	mm	mm	kN/lbf	kg/m
CC1400	81.3	9.5	48.0	38.5	50.0	38.0	500	30.0/6818	1.99