

## Conveyor chains (Z series)

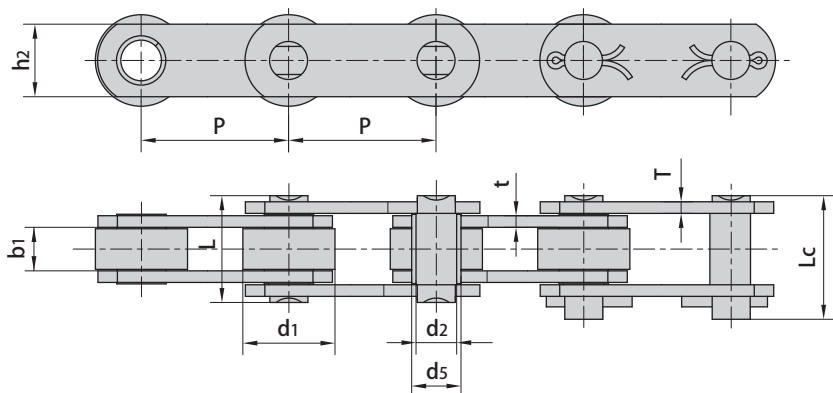

without rollers

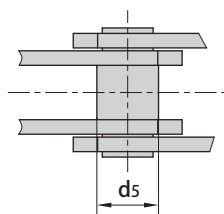

with P large rollers type

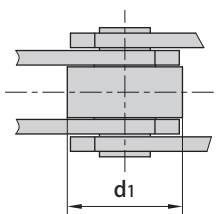

with F flanged rollers type

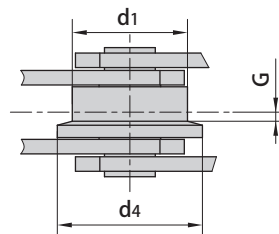

Donghua Chain No.	Pitch							Roller dimension			Bush diameter
	P							d1 max	d4 max	G	d5 max
	mm							mm	mm	mm	mm
Z40	50.8	63.5	76.2	88.9	101.6	127.0	152.4	31.75	40.0	2.5	17.0
Z100	76.2	88.9	101.6	127.0	152.4	177.8	203.2	47.50	60.0	3.5	23.0
Z160	101.6	127.0	152.4	177.8	203.2	228.6	254.0	66.70	82.0	3.5	33.0
Z300	152.4	177.8	203.2	254.0	304.8	-	-	88.90	114.0	8.5	38.0

Donghua Chain No.	Width between inner plates	Pin diameter	Plate depth	Pin length		Plate thickness	Breaking load	
	b1 min	d2 max	h2 max	L max	Lc max	t/T max	Q min	*Q min
	mm	mm	mm	mm	mm	mm	kN/lbf	kN/lbf
Z40	15.0	14.0	25.0	37.0	40.5	4.0	40.0/9091	50.0/11362
Z100	19.0	19.0	40.0	45.0	50.5	5.0/4.0	100.0/22725	130.0/29540
Z160	26.0	26.9	50.0	58.0	63.5	7.0/5.0	156.0/35451	200.0/45454
Z300	38.0	32.0	60.0	84.0	94.0	10.0/8.0	300.0/68175	380.0/86362

\*Q denotes the ultimate tensile strength after hardened