

Conveyor chains with outboard rollers

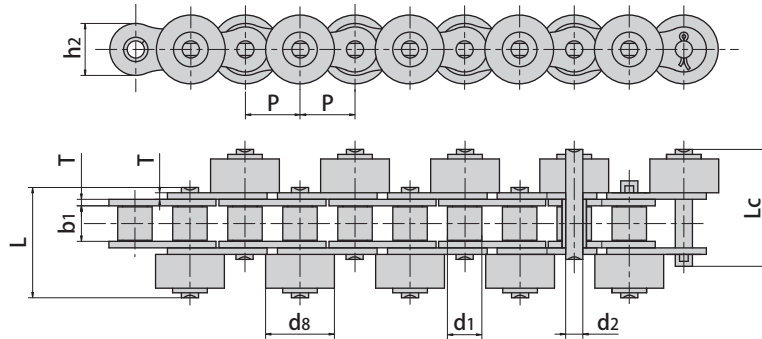

Donghua Chain No.	Pitch		Roller diameter		Width between inner plates		Pin diameter		Pin length		Plate dimension		Ultimate tensile strength	Average tensile strength	Weight per meter
	P	d1 max	d8 max	b1 min	d2 max	L max	Lc max	h2 max	T max	Q min	Q0	q			
	mm	mm	mm	mm	mm	mm	mm	mm	mm	kN/lbf	kN	kg/m			
*40S	12.700	7.95	15.88	7.85	3.96	25.8	27.0	12.0	1.50	13.8/3102	17.5	0.9			
40-PSR	12.700	7.95	15.88	7.85	3.96	25.8	27.0	12.0	1.50	13.8/3102	17.5	1.6			
50-SR-C	15.875	10.16	19.05	9.40	5.08	31.8	34.0	15.1	2.03	21.8/4900	29.4	2.4			
*60S	19.050	11.91	22.23	12.57	5.94	40.0	42.5	18.0	2.42	31.8/7227	41.5	1.9			
*80S	25.400	15.88	28.58	15.75	7.92	51.3	54.3	24.0	3.25	56.7/12886	69.4	3.6			
80S-C	25.400	15.88	28.58	15.75	7.92	51.3	54.3	24.0	3.25	56.7/12886	69.4	5.8			

Note: * means roller made in plastic.

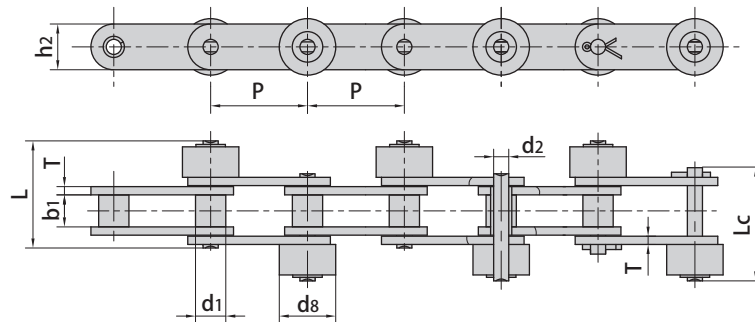

Donghua Chain No.	Pitch		Roller diameter		Width between inner plates		Pin diameter		Pin length		Plate dimension		Ultimate tensile strength	Average tensile strength	Weight per meter
	P	d1 max	d8 max	b1 min	d2 max	L max	Lc max	h2 max	T max	Q min	Q0	q			
	mm	mm	mm	mm	mm	mm	mm	mm	mm	kN/lbf	kN	kg/m			
C2040S2-PSR	25.40	7.95	15.88	7.85	3.96	25.8	27.0	12.0	1.50	13.8/3137	15.18	0.99			
C2050S	31.75	10.16	19.05	9.40	5.08	31.8	34.0	15.0	2.03	21.8/4955	23.90	1.52			
C2052SF1	31.75	19.05	27.00	9.40	5.08	35.0	37.3	15.0	2.03	21.8/4955	23.90	3.06			
*C2060HS	38.10	11.91	22.23	12.57	5.94	44.0	46.6	18.0	3.25	31.1/7069	42.70	1.78			
C2082HSF2	50.80	28.58	40.00	15.75	7.92	54.6	57.8	24.0	4.00	55.6/12500	69.40	6.64			
*C2100HS-P	63.50	19.05	39.69	18.90	9.53	65.3	68.6	30.0	4.80	86.7/19490	109.20	4.44			

Note:*means roller made in plastic

Conveyor chains with outboard rollers

CONVEYOR CHAINS

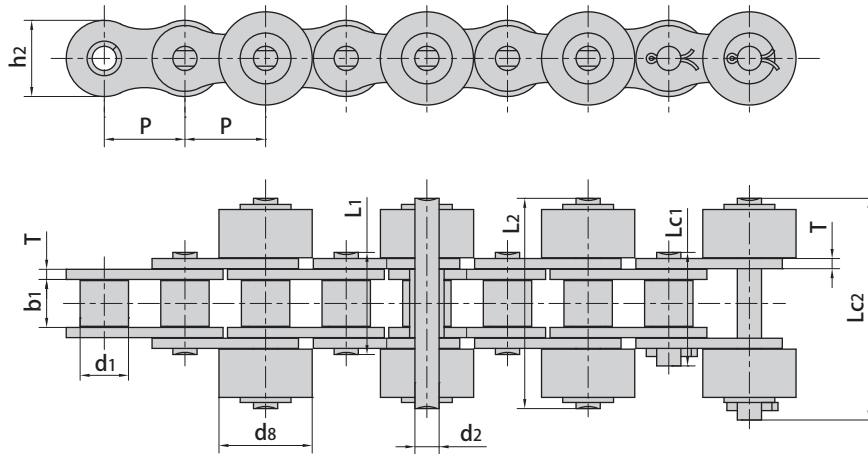

Donghua Chain No.	Pitch	Roller diameter		Width between inner plates	Pin diameter	Pin length				Plate dimension		Ultimate tensile strength	Weight per meter
	P	d1 max	d8 max	b1 min	d2 max	L1 max	L2 max	Lc1 max	Lc2 max	h2 max	T max	Q min	q
	mm	mm	mm	mm	mm	mm	mm	mm	mm	mm	mm	kN/lbf	kg/m
40S2-SR	12.700	7.95	15.88	7.85	3.96	16.6	35.3	18.8	37.2	12.00	1.50	14.1/3169	1.64
50SF1-C	15.875	10.16	19.05	9.40	5.08	20.7	42.8	23.3	45.0	15.09	2.03	21.8/4900	2.41
60S2-C	19.050	11.91	22.23	12.57	5.94	25.9	54.0	28.3	56.6	18.00	2.42	31.8/7149	3.62
100S2	31.750	9.53	36.70	18.90	9.53	40.4	83.0	44.7	87.0	30.00	4.00	86.7/49490	9.09

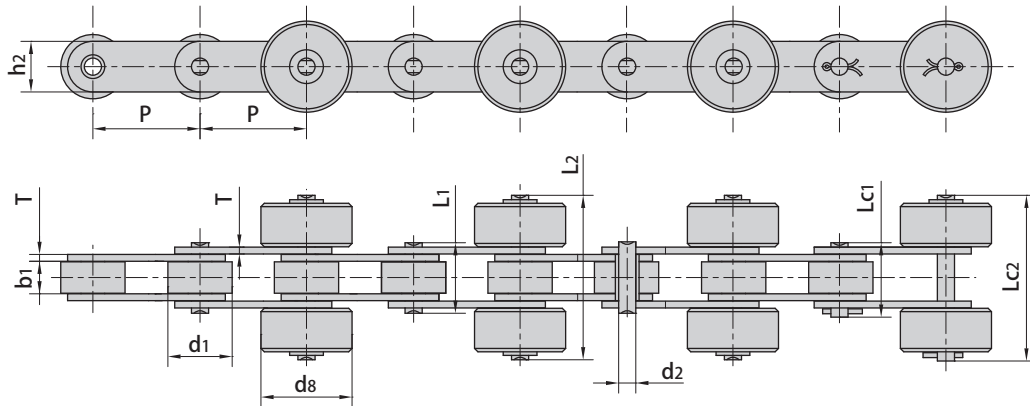

Donghua Chain No.	Pitch	Roller diameter		Width between inner plates	Pin diameter	Pin length				Plate dimension		Ultimate tensile strength	Weight per meter
	P	d1 max	d8 max	b1 min	d2 max	L1 max	L2 max	Lc1 max	Lc2 max	h2 max	T max	Q min	q
	mm	mm	mm	mm	mm	mm	mm	mm	mm	mm	mm	kN/lbf	kg/m
C2050S2	31.75	10.16	19.05	9.40	5.08	/	42.8	/	45.0	15.0	2.03	21.8/4899	2.20
*C2052SF2-P25.4	31.75	19.05	25.40	9.40	5.08	20.7	49.2	23.3	51.1	15.0	2.03	21.8/4900	1.23
C2060HS-C	38.10	11.91	30.00	12.57	5.94	29.2	57.6	31.6	59.2	18.0	3.25	31.8/7149	3.42
C2062HS-C	38.10	22.23	30.00	12.57	5.94	/	57.6	/	59.2	18.0	3.25	31.8/7149	5.97

Note: * means roller made in plastic.