

## Conveyor chains with large rollers

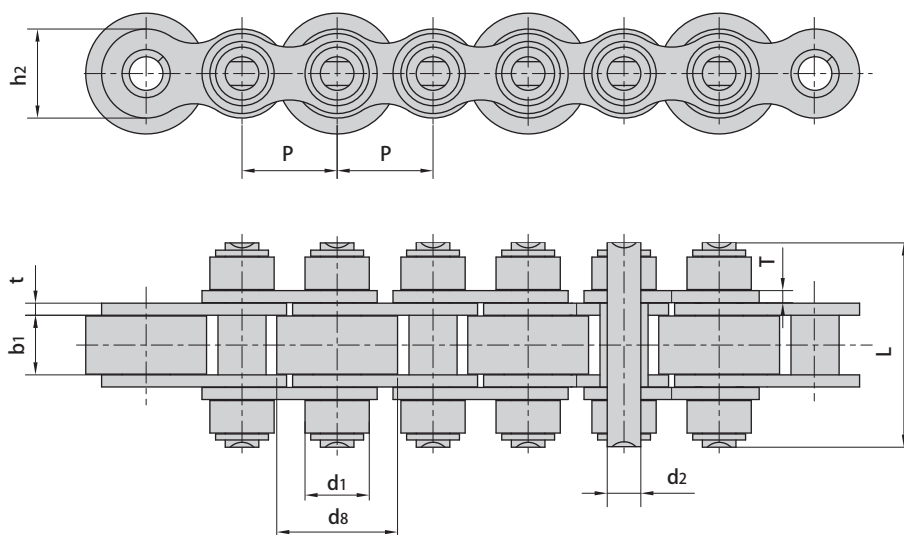

Donghua Chain No.	Pitch	Roller diameter		Width between inner plates	Pin diameter	Pin length	Plate dimension		Ultimate tensile strength	Average tensile strength
	P mm	d1 max mm	d8 max mm	b1 min mm	d2 max mm	L max mm	h2 max mm	t/T max mm	Q min kN/lbf	Q0 kN
08BS-27-P16/C16	12.70	8.51	16.0	7.75	4.45	27.0	11.8	1.60/1.50	18.0/4091	19.8
12BS	19.05	12.07	28.0	11.68	5.72	45.0	16.0	1.85	28.9/6568	31.7
12BS-40-P28/C28	19.05	12.07	28.0	11.68	5.72	40.0	16.0	1.85	29.0/6591	31.7
12BS-43-P26/C26	19.05	12.07	26.0	11.68	5.72	43.0	16.0	1.85	29.0/6591	31.7
12BS-43-P28/C28	19.05	12.07	28.0	11.68	5.72	43.0	16.0	1.85	29.0/6591	31.7
12BS-48-P24/C24	19.05	12.07	24.0	11.68	5.72	48.0	16.0	1.85	29.0/6591	31.7
12BS-48-P26/C26	19.05	12.07	26.0	11.68	5.72	48.0	16.0	1.85	29.0/6591	31.7
12BS-48-P28/C28	19.05	12.07	28.0	11.68	5.72	48.0	16.0	1.85	29.0/6591	31.7
12BS-58-P28/C28	19.05	12.70	28.0	11.68	5.72	58.0	16.0	1.85	29.0/6591	31.7
16BS-65-P38/C38	25.40	15.88	38.0	17.02	8.28	65.0	21.0	4.15/3.10	60.0/13636	72.8
100SF1-85-C45	31.75	19.05	45.0	25.50	9.53	85.0	30.0	4.00	86.7/19490	104.0
212BS-43-P48	38.10	12.07	48.0	11.68	5.72	43.0	16.0	1.85	28.9/6568	31.7

Note: P means roller made in plastic, C means roller made in steel.

## Conveyor chains with large rollers

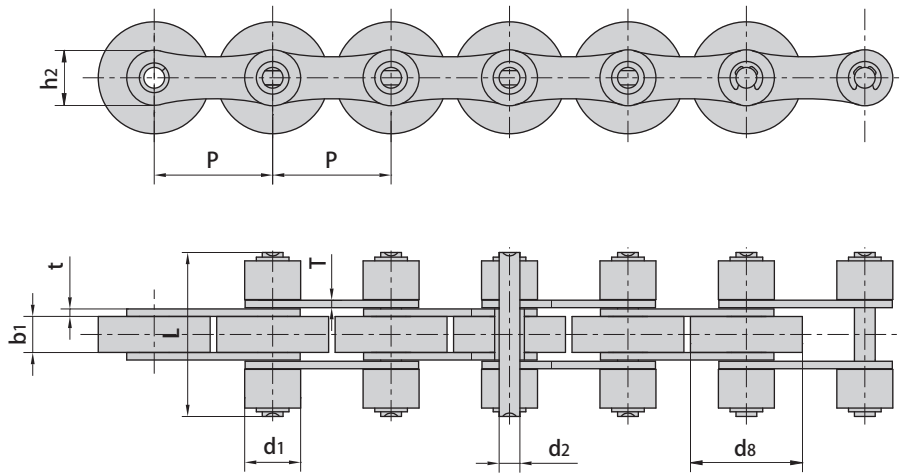

Donghua Chain No.	Pitch	Roller diameter		Width between inner plates	Pin diameter	Pin length	Plate dimension		Ultimate tensile strength	Average tensile strength
	P mm	d1 max mm	d8 max mm	b1 min mm	d2 max mm	L max mm	h2 max mm	t/T max mm	Q min kN/lbf	Q0 kN
16BS-65-C24	25.4	15.88	24.0	17.02	8.28	65.0	21.0	4.15/3.10	60.0/13636	72.8
208BS-35-C24	25.4	12.00	24.0	7.75	4.45	35.0	11.8	1.60	18.0/4091	19.8
*208BSF1-35-P24	25.4	12.00	24.0	7.75	4.45	35.0	11.8	1.60	18.0/4091	19.8
212BS-48-C28	38.1	12.07	28.0	11.68	5.72	48.0	16.0	1.85	28.9/6568	31.7
212BSF2	38.1	12.07	28.0	11.68	5.72	43.0	16.0	1.85	28.9/6568	31.7
212BSF3	38.1	12.07	28.0	11.68	5.72	48.0	16.0	1.85	28.9/6568	31.7
*212BSF4	38.1	12.07	24.0	11.68	5.72	48.0	16.0	1.85	28.9/6568	31.7
212BSF5-43-C28	38.1	12.07	28.0	11.68	5.72	43.0	16.0	1.85	28.9/6568	31.7
*216BS-65-P50	50.8	15.88	50.0	17.02	8.28	65.0	21.0	4.15/3.10	60.0/13636	72.8
216BS-65-C38.5	50.8	15.88	38.5	17.02	8.28	65.0	21.0	4.15/3.10	60.0/13636	72.8
216BS-65-C40	50.8	15.88	40.0	17.02	8.28	65.0	21.0	4.15/3.10	60.0/13636	72.8
63PS	63.0	40.00	50.0	24.50	14.00	91.5	35.0	5.10	90.0/20232	135.0
63PSF1	63.0	38.00	46.0	21.60	12.00	84.0	30.0	4.00	66.68/15000	85.0

Note: \* means roller made in plastic.