

## Conveyor chains with extended pins (M series)

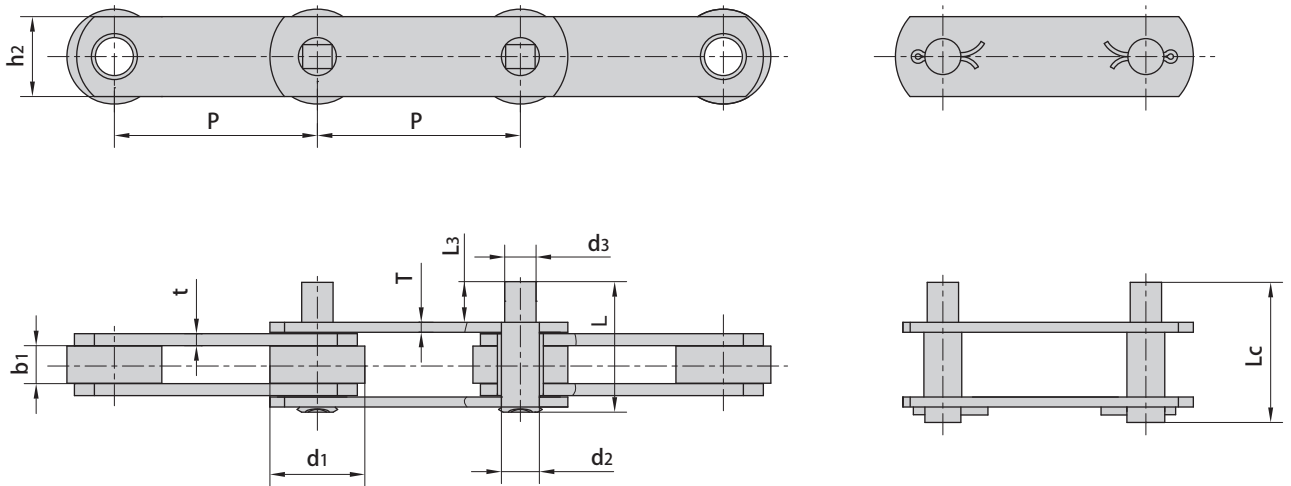

Donghua Chain No.	Pitch	Roller diameter	Width between inner plates	Pin diameter	Extended pin dimension		Pin length		Inner plate depth	Plate thickness
	P	d1 max	b1 min	d2 max	d3 max	L3	L max	Lc max	h2 max	T max
	mm	mm	mm	mm	mm	mm	mm	mm	mm	mm
M18F7-D3-P-75	75.00	25.00	11.50	5.72	12.00	30.0	56.6	58.9	20.0	3.0
M20D1F1.02-P-80	80.00	25.00	16.00	6.00	6.00	25.5	54.7	57.2	18.0	2.5
M75-D3-P-100	100.00	38.00	18.95	9.53	11.00	38.0	76.2	80.5	26.0	4.0
M100F11-P-101.6-D3	101.60	47.50	19.00	19.00	15.70	20.0	66.3	71.5	40.0	6.0/5.0
M100-P-152.4-D3	152.40	47.50	19.00	19.00	18.25	84.8	127.5	132.7	40.0	5.0/4.0
M100-P-203.2-D3	203.20	47.50	19.00	19.00	18.25	84.8	127.5	132.7	40.0	5.0/4.0

Donghua Chain No.	Ultimate tensile strength	Average tensile strength	Weight per meter
	Q <sub>min</sub>	Q <sub>0 min</sub>	q
	kN/lbf	kN	kg/m
M18F7-D3-P-75	18.0/4050	20.00	2.14
M20D1F1.02-P-80	20.0/4545	25.00	1.65
M75-D3-P-100	75.0/16870	82.50	3.61
M100F11-P-101.6-D3	150.0/33722	165.00	7.60
M100-P-152.4-D3	100.0/22496	110.00	6.36
M100-P-203.2-D3	100.0/22496	110.00	5.49