

Conveyor chain special attachments (A series)

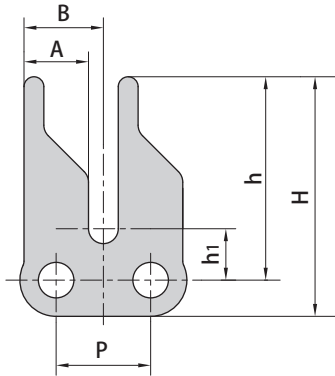

Donghua Chain No.	P	A	B	h ₁	h	H
	mm	mm	mm	mm	mm	mm
06CF2	9.525	6.5	8.0	5.2	20.5	24.15
06CF7	9.525	6.5	8.0	4.1	20.0	24.45

Donghua Chain No.	P	A	B	C	h ₁	h	H
	mm	mm	mm	mm	mm	mm	mm
06CF5	9.525	4.3	2.0	16.9	5.3	16.0	20.0
06CF8	9.525	4.3	2.0	16.9	5.3	20.0	24.0

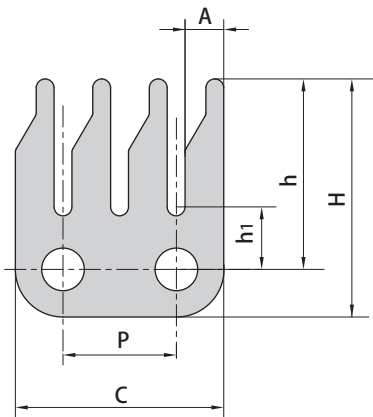
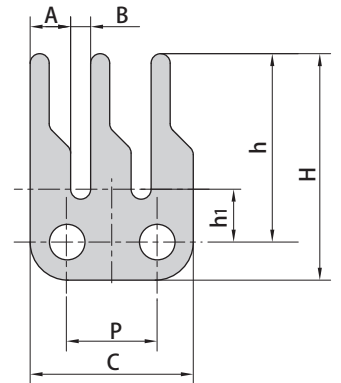

Donghua Chain No.	P	A	C	h ₁	h	H
	mm	mm	mm	mm	mm	mm
06CF6	9.525	3.25	17.5	5.25	16.0	20.0

Donghua Chain No.	P	L	A	B	H
	mm	mm	mm	mm	mm
RS40F1	12.7	23.6	7.32	16.1	13.3

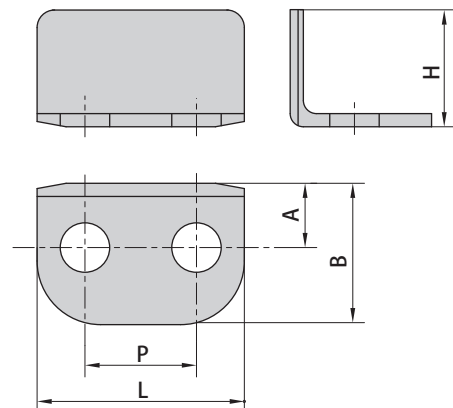

Conveyor chain special attachments (A series)

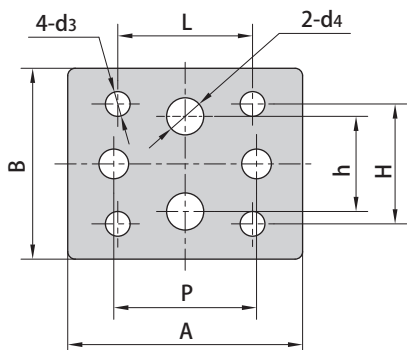

Donghua Chain No.	P	A	B	L	h	H	d3	d4
	mm	mm	mm	mm	mm	mm	mm	mm
08AF7	12.7	31.34	25.48	17.45	12.7	15.88	3.3	4.95

Donghua Chain No.	P	A	B	C	h4
	mm	mm	mm	mm	mm
08AF9-2	12.7	23.0	28.8	16.0	10.0

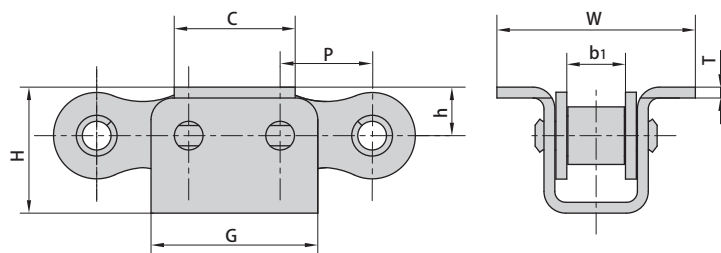
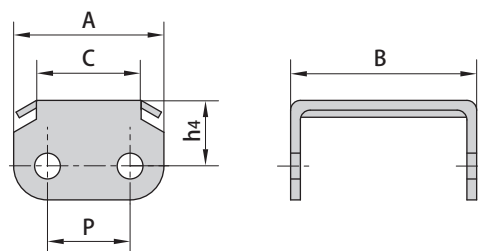

Donghua Chain No.	P	b1	C	G	H	h	W	T
	mm	mm	mm	mm	mm	mm	mm	mm
08A-U1F1	12.7	7.85	16.5	24.5	17.4	7.0	27.4	1.6

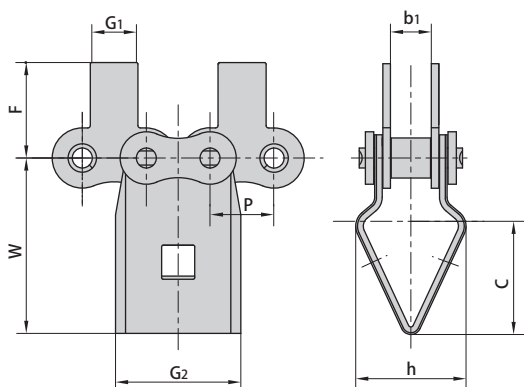

Donghua Chain No.	P	b1	G1	G2	F	W	C	h
	mm	mm	mm	mm	mm	mm	mm	mm
08ASAF1	12.7	7.85	9.5	25.0	19.05	35.0	21.5	22.0

Conveyor chain special attachments (A series)

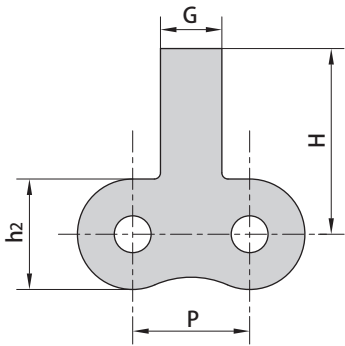

Donghua Chain No.	P	G	H	h2
	mm	mm	mm	mm
12ASA	19.05	10.0	204.0	18.0

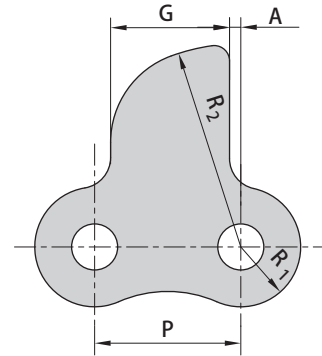

Donghua Chain No.	P	G	A	R1	R2
	mm	mm	mm	mm	mm
12AF7	19.05	15.5	1.47	7.8	26.5

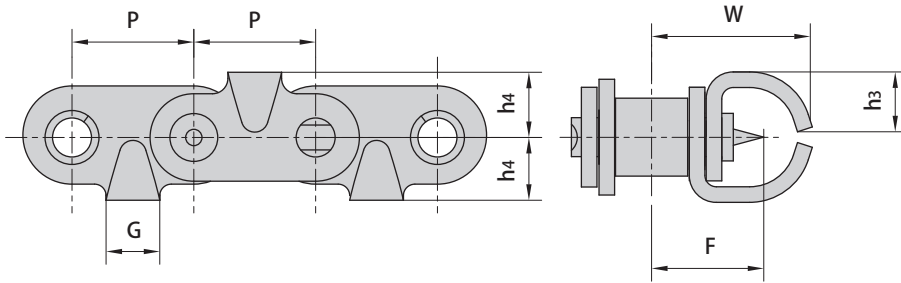

Donghua Chain No.	P	G	F	W	h3	h4
	mm	mm	mm	mm	mm	mm
10AF12	15.875	7.0	14.55	21.2	7.8	8.5

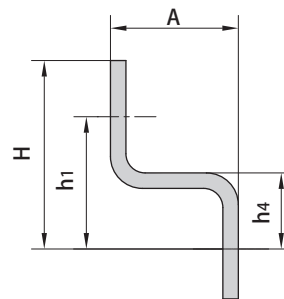
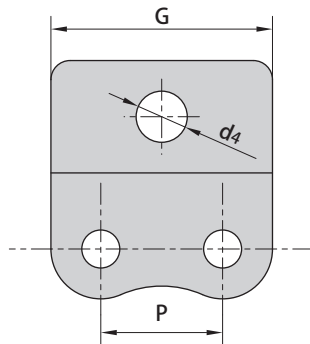

Donghua Chain No.	P	A	G	h1	h4	H	d4
	mm	mm	mm	mm	mm	mm	mm
12AF8	19.05	12.0	37.05	-	12.0	26.50	-
12AF17	19.05	20.0	34.65	20.69	11.9	29.48	8

Conveyor chain special attachments (A series)

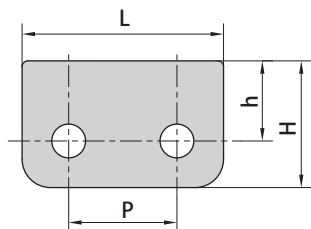

Donghua Chain No.	P	h	H	L
	mm	mm	mm	mm
C60TS	19.05	14.1	22.3	35.45

Donghua Chain No.	P	L	h ₁	h	H	d ₄
	mm	mm	mm	mm	mm	mm
16AF6	25.4	47.63	7.92	21.44	34.93	4.98

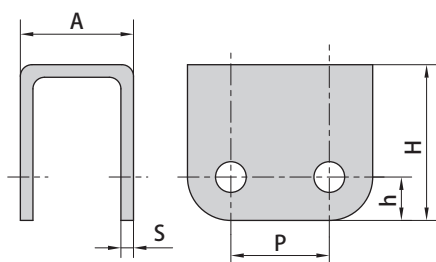
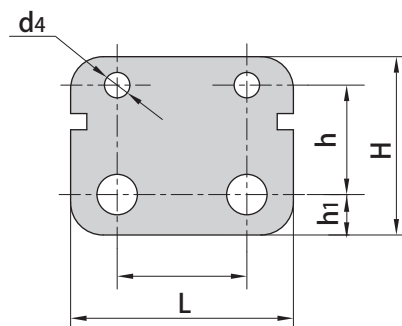

Donghua Chain No.	P	h	H	A	S
	mm	mm	mm	mm	mm
16AF8	25.4	11.2	40.2	29.2	3.1

Donghua Chain No.	P	d ₄	R ₁	R ₂
	mm	mm	mm	mm
16AF13	76.2	45.0	11.9	31.0

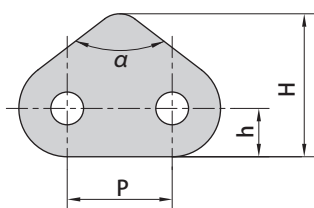
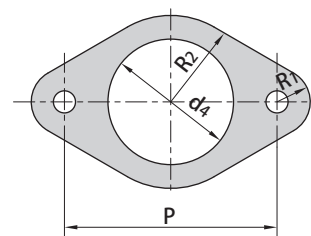

Donghua Chain No.	P	h	H	α
	mm	mm	mm	
20AF2	31.75	12.5	51.0	74°

Donghua Chain No.	P	G	C ₁	C ₂	C ₃	d ₄	α
	mm	mm	mm	mm	mm	mm	
20ASK1F1	31.75	25.4	23.0	30.0	40.0	8.7	75°

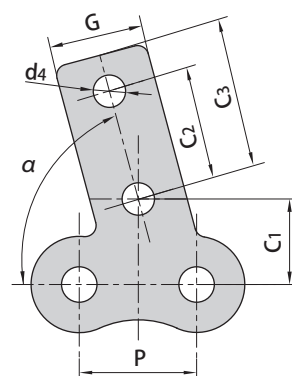

Conveyor chain special attachments (A series)

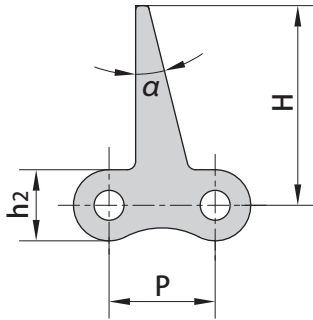

Donghua Chain No.	P mm	H mm	h ₂ mm	α
41F5	12.7	23.9	8.51	14°

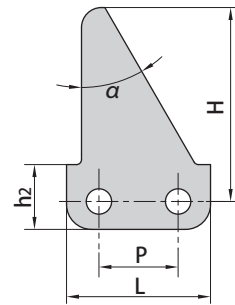

Donghua Chain No.	P mm	H mm	h ₂ mm	L mm	α
10ASA0F1	15.875	38.5	13	29.5	30°

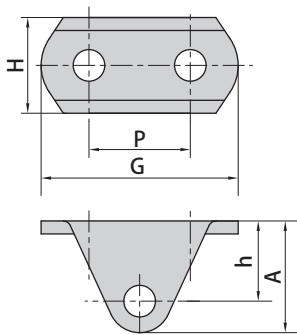

Donghua Chain No.	P mm	H mm	h mm	G mm	A m
16AF21	25.4	24	20.1	49.4	28.1

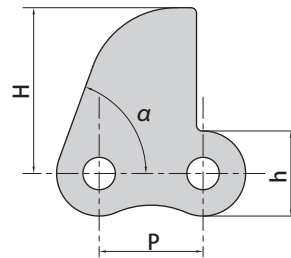

Donghua Chain No.	P mm	H mm	h mm	α
12AHF27	19.05	30.2	15.6	70°

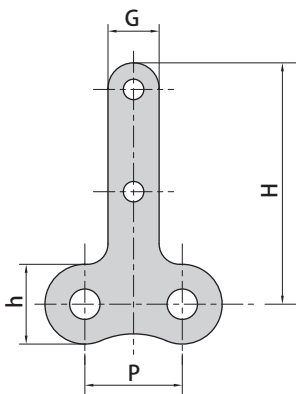

Donghua Chain No.	P mm	H mm	h mm	G mm
12AHF30	19.05	47.2	15.6	10

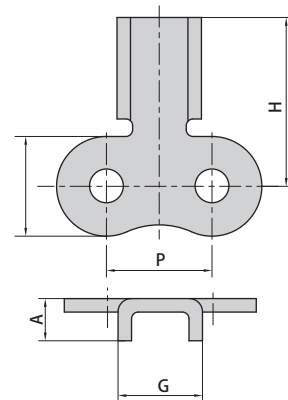

Donghua Chain No.	P mm	H mm	h mm	A mm	G mm
10AF25	15.875	25.4	15	6.35	12.7

Conveyor chain special attachments (A series)

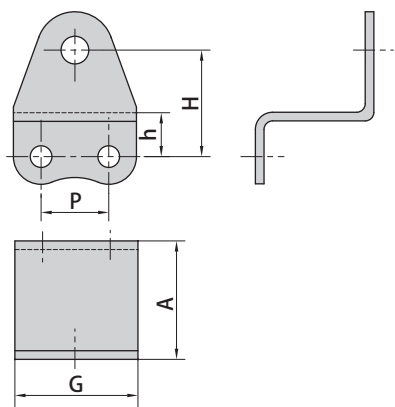

Donghua Chain No.	P mm	H mm	h mm	A mm	G mm
10AF17	15.875	25	10.3	27.8	28.88

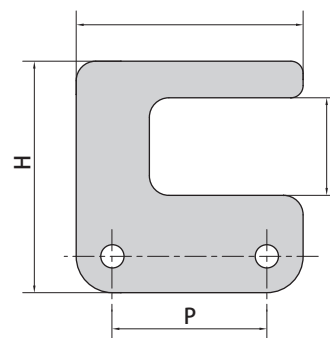
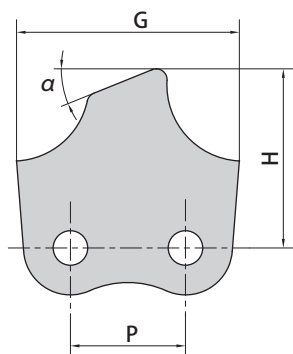
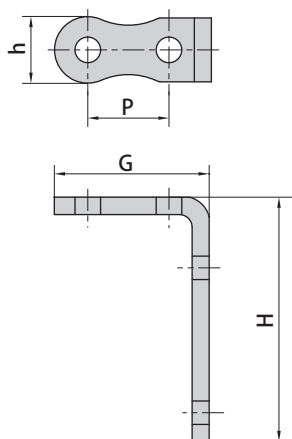

Donghua Chain No.	P mm	H mm	h mm	G mm
12AF44	19.05	55	15.6	36.85

Donghua Chain No.	P mm	H mm	G mm	α
20AF21	31.75	49.46	61.5	22°

Donghua Chain No.	P mm	H mm	h mm	G mm
20AF18	63.5	40	15	93

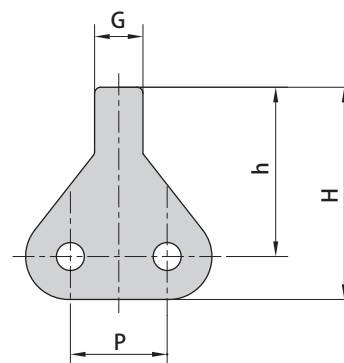
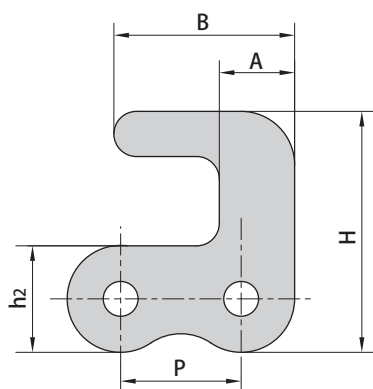

Donghua Chain No.	P mm	h ₂ mm	H mm	A mm	B mm
05BF1	8.0	7.1	16.0	5.0	12.0

Donghua Chain No.	P mm	H mm	h mm	G mm
05BF3	8	17.55	14	4