

## Conveyor chains for hoisting cinder

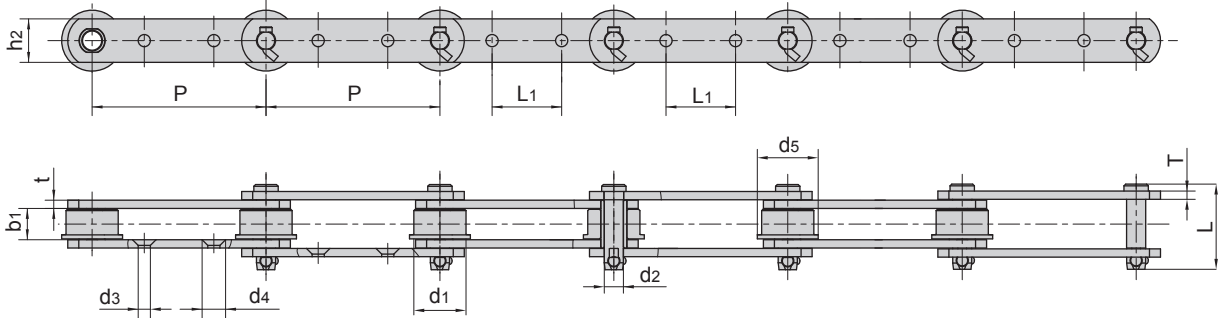

Donghua Chain No.	Pitch	Width between inner plates	Roller diameter		Pin diameter	Pin length	Plate depth	Plate thickness	Attachment dimension			Ultimate tensile strength	Weight per meter
	P mm	b1 min mm	d1 max mm	d5 max mm	d2 max mm	L max mm	h2 max mm	t/T max mm	L1 max mm	d3 max mm	d4 max mm	Q0 min kN/lbf	q kg/m
P200F70	200	35	60	70	22	98	50	9.5	80	14	27	320/71940	13.52

## Scraper conveyor chains

Direction of travel →

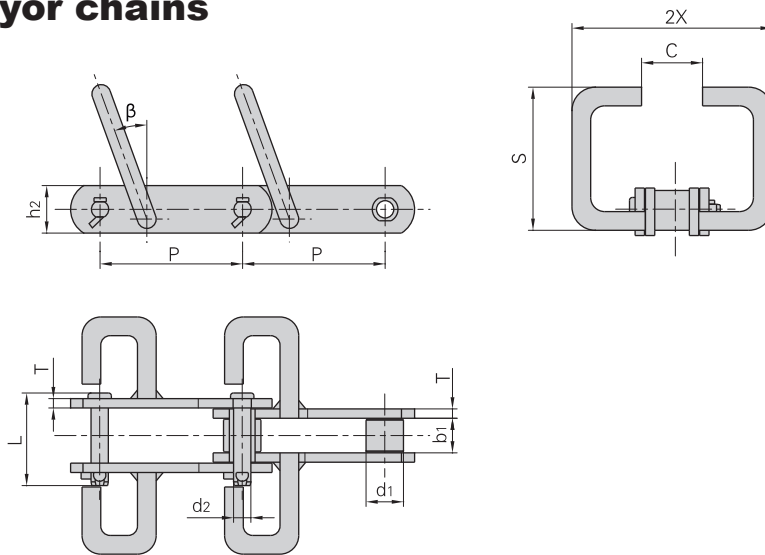

Donghua Chain No.	Pitch	Roller diameter	Width between inner plates	Pin diameter	Pin length	Plate depth	Plate thickness	Attachment dimension			Ultimate tensile strength	Weight per meter	
	P mm	d1 max mm	b1 mm	d2 mm	L mm	h2 mm	T mm	S mm	2X mm	C mm	β	Q kN/lbf	q kg/m
P152F51	152.4	40	36	18.5	95.5	50.8	10	175	310	110	20°	170/38242	24.9