

Conveyor chains for crawler asphalt paver

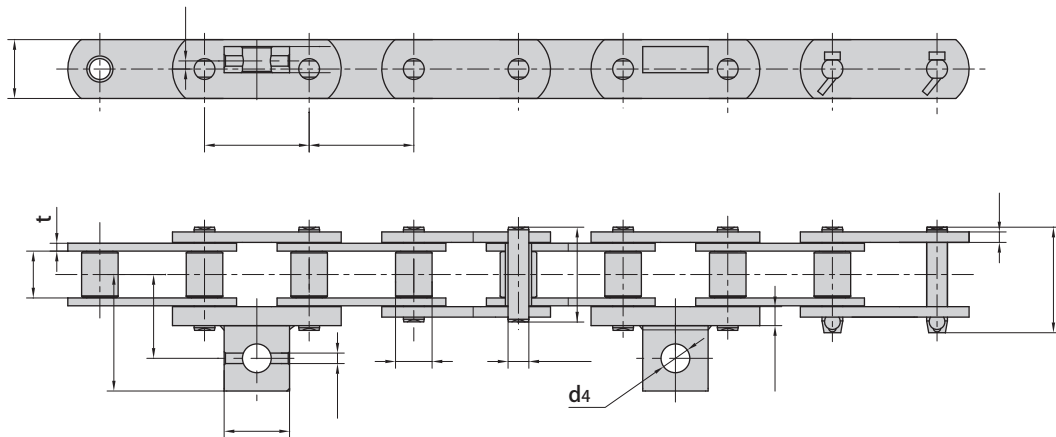

Donghua Chain No.	F	W	G	h ₄	d ₄	d ₅	T ₁
	mm	mm	mm	mm	mm	mm	mm
P80F7	56.4	81.4	50.5	5.0	21.0	8.2	6.2
P80F8	63.0	88.0	50.0	8.0	22.0	10.2	14.2
P80F17	66.3	91.3	50.0	—	24.0	-	15.0
P80F19	56.5	81.5	50.0	6.2	22.0	8.0	8.0
P80F21	57.0	82.0	50.0	—	21.5	-	8.0
*P80F27	56.2	81.5	50.5	—	21.0	-	6.2
P80F29	56.5	81.5	50.0	6.2	22.0	10.0	8.0
P80F45	57.5	80.0	50.0	—	25.0	-	8.0
*P80F51A1	57.0	82.0	50.0	—	20.5	-	8.0

Donghua Chain No.	Pitch	Roller diameter	Width between inner plates	Pin diameter	Pin length		Plate depth	Plate thickness	Ultimate tensile strength	Weight per meter
	P	d ₁ max	b ₁ min	d ₂ max	L max	L _c max	h ₂ max	t/T max	Q min	q
	mm	mm	mm	mm	mm	mm	mm	mm	kN/lbf	kg/m
P80F7	80.0	35.76	35.3	18.00	72.0	76.7	46.00	7.0/6.2	95.0/21370	11.91
P80F8	80.0	27.94	33.8	15.90	68.4	76.0	44.45	6.0/8.0	190.0/42741	10.80
P80F17	80.0	36.00	35.3	18.00	81.0	81.5	45.00	6.0/5.0	195.0/43866	12.90
P80F19	80.0	27.94	33.8	15.90	68.4	75.8	45.00	6.0/8.0	190.0/42741	11.20
P80F21	80.0	27.94	34.0	15.90	78.4	-	45.00	6.0/8.0	190.0/42741	10.70
*P80F27	80.0	26.00	35.3	18.00	72.0	76.7	46.00	7.0/6.2	195.0/43866	9.55
P80F29	80.0	27.94	33.8	15.90	70.4	74.0	45.00	6.0/8.0	190.0/42741	10.80
P80F45	80.0	32.00	35.0	15.90	70.6	78.0	45.00	6.0/8.0	190.0/42741	10.94
*P80F51A1	80.0	26.00	35.0	15.90	69.5	77.0	45.00	6.0/8.0	175.0/39340	10.42

*Bush chain: d₁ in the table indicates the external diameter of the bush.

Conveyor chains for crawler asphalt paver

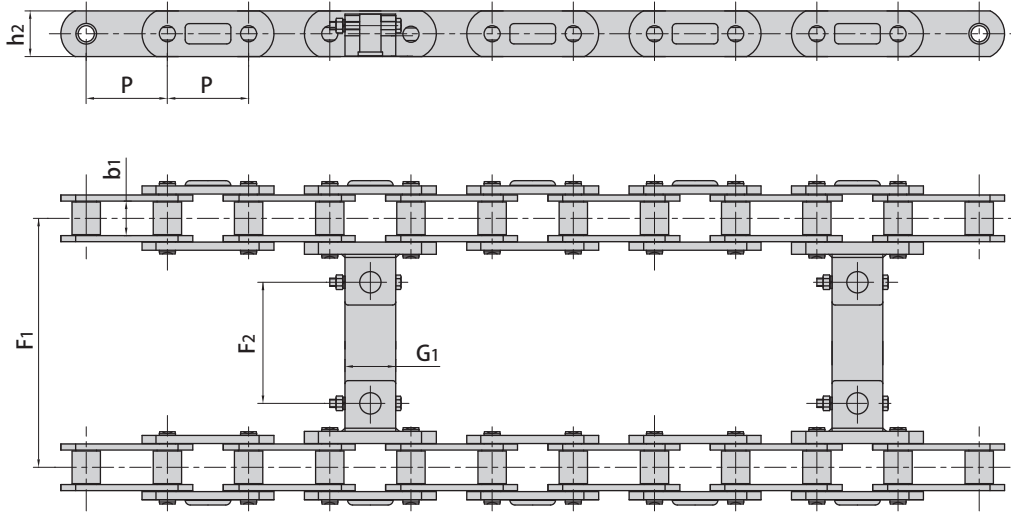

Donghua Chain No.	P	b1	h2	F1	F2	G1
	mm	mm	mm	mm	mm	mm
P80F8	80.0	33.8	45.0	575.0	449.0	50.0
P80F17	80.0	35.3	45.0	575.0	442.4	50.0
P80F41	80.0	33.8	45.0	509.5	396.5	50.0
P80F27	80.0	35.3	46.0	497.4	385.0	50.0
TPJP80F1	80.0	33.8	45.0	500.0	374.0	50.0
P80F45	80.0	35.0	45.0	540.0	425.0	50.0
TPJP80F3	80.0	33.8	45.0	561.0	448.0	50.0

