

## Self-lubrication roller chains

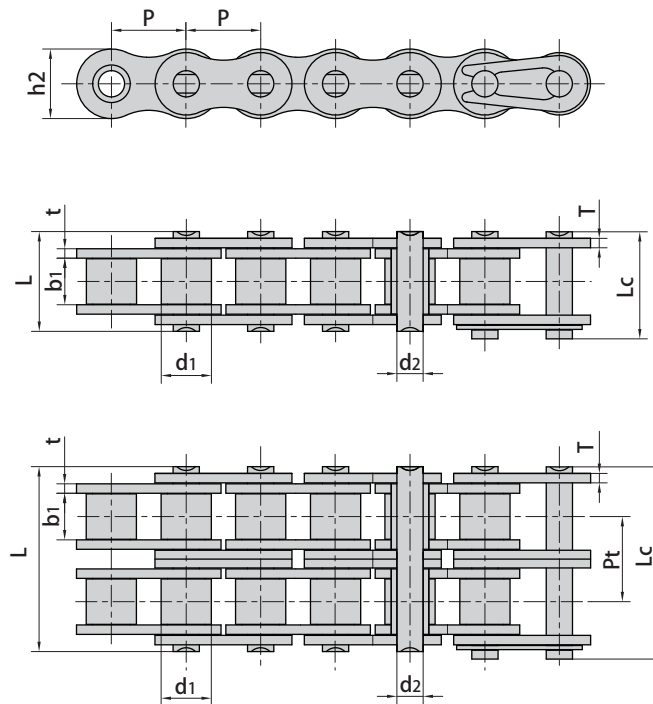

Donghua Chain No.	Pitch	Roller diameter	Width between inner plates	Pin diameter	Pin length		Inner plate depth	Plate thickness	Transverse pitch	Ultimate tensile strength	Weight per meter
	p	d1 max	b1 min	d2 max	L max	Lc max	h2 max	t/T max	Pt	Q min	q
	mm	mm	mm	mm	mm	mm	mm	mm	mm	kN/lbf	kg/m
#06BSLR	9.525	6.35	5.72	3.28	13.15	14.1	8.20	1.30	-	9.0/2045	0.41
08BSLR	12.700	8.51	7.75	4.45	16.70	18.2	11.80	1.60	-	18.0/4091	0.69
08BSLRF1	12.700	8.51	7.75	4.45	17.30	18.7	11.80	1.60	-	18.0/4091	0.72
10BSLR	15.875	10.16	9.65	5.08	19.50	20.9	14.70	1.70	-	22.4/5091	0.93
10BSLRF1	15.875	10.16	9.65	5.08	19.90	21.6	14.70	1.70	-	22.4/5091	0.97
10BSLRF2	15.875	10.16	9.65	5.08	19.50	20.9	14.70	1.70	-	14.0/3181	1.20
#C10BSLR	15.875	10.16	9.65	5.08	19.50	20.9	14.70	1.70	-	22.4/5089	1.06
12BSLR	19.050	12.07	11.68	5.72	22.50	24.2	16.00	1.85	-	29.0/6591	1.15
12BSLRF1	19.050	12.07	11.68	5.72	22.90	24.7	16.00	1.85	-	29.0/6591	1.19
#C12BSLR	19.050	12.07	11.68	5.72	22.90	24.9	16.00	1.85	-	29.0/6589	1.32
16BSLR	25.400	15.88	17.02	8.28	36.10	37.4	21.00	4.15/3.1	-	60.0/13636	2.71
16BSLRF1	25.400	15.88	17.02	8.28	36.70	39.7	21.00	4.15/3.1	-	60.0/13636	2.73
16BSLRF4	25.400	15.88	17.02	8.28	36.10	39.1	21.00	4.15/3.1	-	60.0/13636	2.77
#C16BF1SLR	25.400	15.88	17.02	8.28	36.10	37.4	24.00	4.15	-	60.0/13633	3.38
#C16BSLRF1	25.400	15.88	17.02	8.28	36.70	39.7	21.00	4.15/3.1	-	60.0/13633	2.98
#C16BSLRF2	25.400	15.88	17.02	8.28	36.70	38.2	24.00	4.15/3.1	-	60.0/13633	3.39

#Straight side plates

# Self-lubrication roller chains

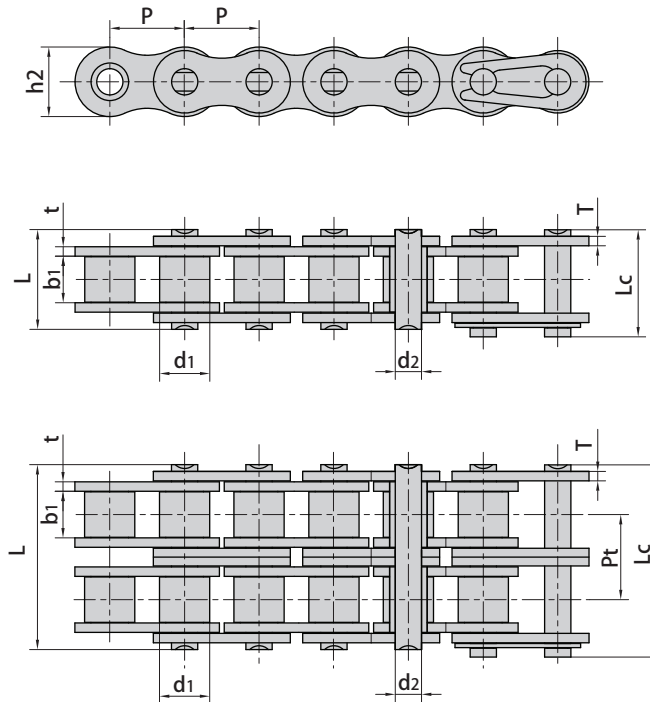

Donghua Chain No.	Pitch	Roller diameter	Width between inner plates	Pin diameter	Pin length		Inner plate depth	Plate thickness	Transverse pitch	Ultimate tensile strength	Weight per meter
	P mm	d1 max mm	b1 min mm	d2 max mm	L max mm	Lc max mm	h2 max mm	t/T max mm	Pt mm	Q min kN/lbf	q kg/m
40SLR	12.700	7.95	7.85	3.96	16.60	17.8	12.00	1.50	-	14.1/3205	0.62
50SLR	15.875	10.16	9.40	5.08	20.70	22.2	15.09	2.03	-	22.0/5045	1.02
60SLR	19.050	11.91	12.57	5.94	27.50	29.3	18.00	3.25/2.42	-	34.2/7772	1.65
60HSLR	19.050	11.91	12.57	5.94	29.20	31.0	18.00	3.25	-	31.8/7227	1.95
#C60SLR	19.050	11.91	12.57	5.94	25.90	27.7	18.20	2.42	-	31.8/7227	1.83
80SLR	25.400	15.88	15.75	7.92	32.70	35.0	24.00	3.25	-	56.7/12886	2.60
80HSLR	25.400	15.88	15.75	7.92	36.20	38.9	24.00	4.00	-	56.7/12886	3.03
#C80SLR	25.400	15.88	15.75	7.92	32.70	35.0	24.00	3.25	-	56.7/12886	3.10
100SLR	31.750	19.05	18.90	9.53	40.40	44.7	30.00	4.00	-	86.7/19699	3.94
08BSLR-2	12.700	8.51	7.75	4.45	31.20	32.2	11.80	1.60	13.92	32.0/7273	1.34
10BSLR-2	15.875	10.16	9.65	5.08	36.10	37.5	14.70	1.70	16.59	44.5/10114	1.84
12BSLR-2	19.050	12.07	11.68	5.72	42.00	43.6	16.00	1.85	19.46	57.8/13136	2.31
#C12BSLR-2	19.050	12.07	11.68	5.72	42.00	43.6	16.00	1.85	19.46	57.8/13136	2.31
16BSLR-2	25.400	15.88	17.02	8.28	68.00	69.3	21.00	4.15/3.1	31.88	106.0/24091	5.42
40SLR-2	12.700	7.95	7.85	3.96	31.00	32.2	12.00	1.50	14.38	28.2/6409	1.12
50SLR-2	15.875	10.16	9.40	5.08	38.90	40.4	15.09	2.03	18.11	44.4/10091	2.00
60SLR-2	19.050	11.91	12.57	5.94	50.30	52.1	18.00	2.42	22.78	68.4/15544	3.21
80SLR-2	25.400	15.88	15.75	7.92	62.70	64.3	24.00	3.25	29.29	113.4/25773	5.15
100SLR-2	31.750	19.05	18.90	9.53	76.40	80.5	30.00	4.00	35.76	173.4/39399	7.89

#Straight side plates