

## Double pitch transmission chains

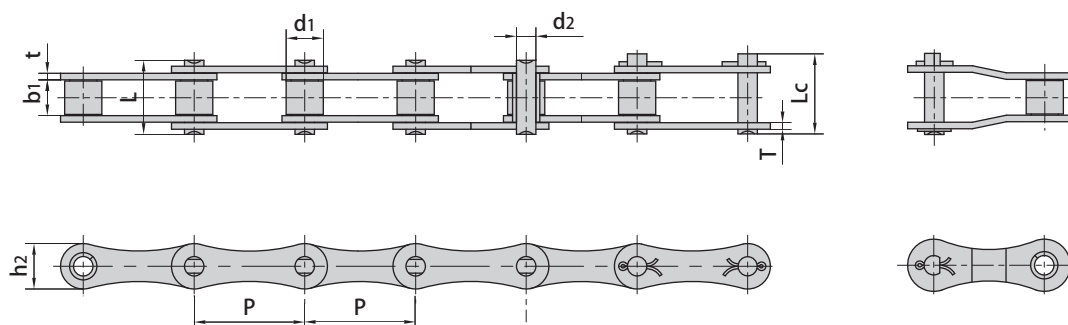

DIN/ISO Chain No.	ANSI Chain No.	Pitch	Roller diameter	Width between inner plates	Pin diameter	Pin length		Inner plate depth	Plate thickness	Ultimate tensile strength	Average tensile strength	Weight per meter
		P	d1 max	b1 min	d2 max	L max	Lc max	h2 max	t/T max	Q min	Q0	q
		mm	mm	mm	mm	mm	mm	mm	mm	kN/lbf	kN	kg/m
208A	2040	25.40	7.95	7.85	3.96	16.6	17.8	12.0	1.50	14.1/3205	16.7	0.42
208B		25.40	8.51	7.75	4.45	16.7	18.2	11.8	1.60	18.0/4091	19.4	0.45
210A	2050	31.75	10.16	9.40	5.08	20.7	22.2	15.0	2.03	22.2/5045	28.1	0.73
210B		31.75	10.16	9.65	5.08	19.5	20.9	14.7	1.70	22.4/5091	27.5	0.65
212A	2060	38.10	11.91	12.57	5.94	25.9	27.7	18.0	2.42	31.8/7227	36.8	1.02
212B		38.10	12.07	11.68	5.72	22.5	25.2	16.0	1.85	29.0/6591	32.2	0.76
216A	2080	50.80	15.88	15.75	7.92	32.7	36.5	24.0	3.25	56.7/12886	65.7	1.70
216AH	2080H	50.80	15.88	15.75	7.92	36.2	39.4	24.0	4.00	56.7/12886	70.0	2.17
216B		50.80	15.88	17.02	8.28	36.1	39.1	21.0	4.15/3.1	60.0/13636	72.8	1.75
220A	2100	63.50	19.05	18.90	9.53	40.4	44.7	30.0	4.00	88.5/20114	102.6	2.55
220B		63.50	19.05	19.56	10.19	41.3	45.0	26.4	4.5/3.5	95.0/14773	106.7	2.62
224A	2120	76.20	22.23	25.22	11.10	50.3	54.3	35.7	4.80	127.0/28864	147.3	4.06
224B		76.20	25.40	25.40	14.63	53.4	57.8	33.2	6.0/4.8	160.0/36364	178.0	4.70
228B		88.90	27.94	30.99	15.90	65.1	69.5	36.7	7.5/6.0	200.0/45455	222.0	6.23
232B		101.60	29.21	30.99	17.81	66.0	71.0	42.0	7.0/6.0	250.0/56818	277.5	6.72