

Corrosion resistant/Zinc-plated chains

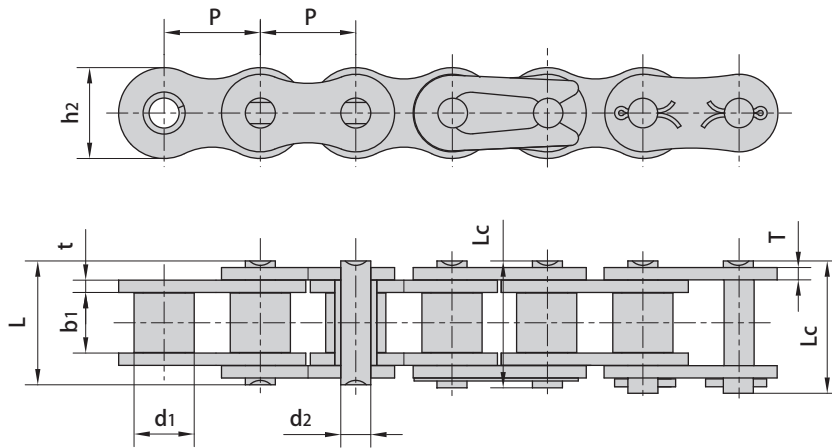

Donghua Chain No.	Pitch	Roller diameter	Width between inner plates	Pin diameter	Pin length		Inner plate depth	Plate thickness	Breaking load	Weight per meter
	P	d1 max	b1 min	d2 max	L max	Lc max	h2 max	t/T max	Q	q
	mm	mm	mm	mm	mm	mm	mm	mm	kN/lbf	kg/m
*25ZP	6.350	3.30	3.18	2.31	7.90	8.40	6.00	0.80	3.50/795	0.15
*35ZP	9.525	5.08	4.77	3.58	12.40	13.17	9.00	1.30	7.90/1795	0.33
41ZP	12.700	7.77	6.25	3.58	13.75	15.00	9.91	1.30	6.67/1516	0.41
40ZP	12.700	7.95	7.85	3.96	16.60	17.80	12.00	1.50	14.10/3205	0.62
50ZP	15.875	10.16	9.40	5.08	20.70	22.20	15.09	2.03	22.20/5045	1.02
60ZP	19.050	11.91	12.57	5.94	25.90	27.70	18.00	2.42	31.80/7227	1.50
80ZP	25.400	15.88	15.75	7.92	32.70	35.00	24.00	3.25	56.70/12886	2.60
100ZP	31.750	19.05	18.90	9.53	40.40	44.70	30.00	4.00	88.50/20114	3.91
120ZP	38.100	22.23	25.22	11.10	50.30	54.30	35.70	4.80	127.00/28864	5.62
140ZP	44.450	25.40	25.22	12.70	54.40	59.00	41.00	5.60	172.40/39182	7.50
160ZP	50.800	28.58	31.55	14.27	64.80	69.60	47.80	6.40	226.80/51545	10.10
04BZP	6.000	4.00	2.80	1.85	6.80	7.80	5.00	0.60	3.00/682	0.11
05BZP	8.000	5.00	3.00	2.31	8.20	8.90	7.10	0.80	5.00/1136	0.20
#06BZP	9.525	6.35	5.72	3.28	13.15	14.10	8.20	1.30	9.00/2045	0.41
08BZP	12.700	8.51	7.75	4.45	16.70	18.20	11.80	1.60	18.00/4091	0.69
10BZP	15.875	10.16	9.65	5.08	19.50	20.90	14.70	1.70	22.40/5091	0.93
12BZP	19.050	12.07	11.68	5.72	22.50	24.20	16.00	1.85	29.00/6591	1.15
16BZP	25.400	15.88	17.02	8.28	36.10	37.40	21.00	4.15/3.1	60.00/13636	2.71
20BZP	31.750	19.05	19.56	10.19	41.30	45.00	26.40	4.5/3.5	95.00/21591	3.70
24BZP	38.100	25.40	25.40	14.63	53.40	57.80	33.20	6.0/4.8	160.0/36364	7.10
28BZP	44.450	27.94	30.99	15.90	65.10	69.50	36.70	7.5/6.0	200.0/45455	8.50
32BZP	50.800	29.21	30.99	17.81	66.00	71.00	42.00	7.0/6.0	250.0/56818	10.25

*Bush chain: d1 in the table indicates the external diameter of the bush.

#Straight side plates

Note: Duplex & Triplex zinc plated chains are available in all sizes

Double pitch zinc plated conveyor chains are available upon request