

Conveyor chains with attachments

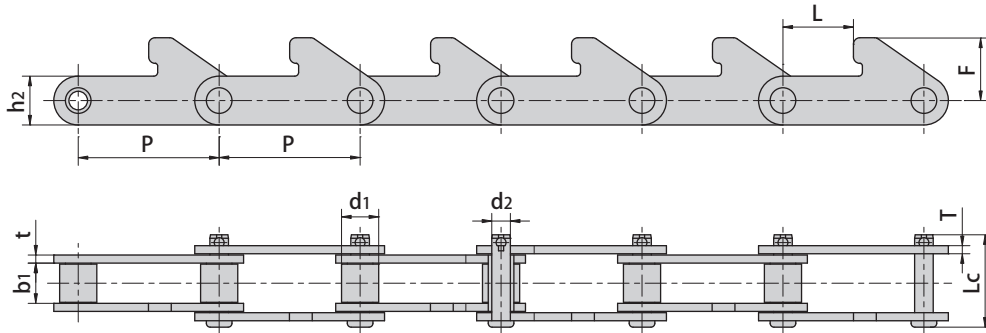

Donghua Chain No.	Pitch	Roller diameter	Width between inner plates	Pin diameter	Pin length	Plate depth	Plate thickness	Attachment dimension		Ultimate tensile strength	Average tensile strength	Weight per meter
	P	d1 max	b1 min	d2 max	Lc max	h2 max	t/T max	F	L	Q min	Q0	q
	mm	mm	mm	mm	mm	mm	mm	mm	mm	kN/lbf	kN	kg/m
P110F6	110.0	29.0	30.4	14.5	72.1	38.1	6.3	49.05	55.0	229.0/51484	250.0	7.0

Bottle washer conveyor chain

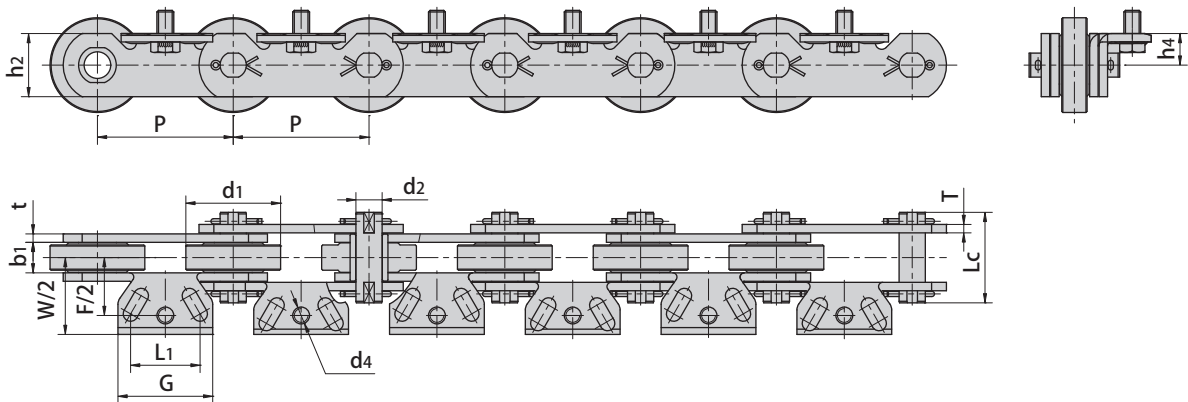

Donghua Chain No.	Pitch	Roller diameter	Width between inner plates	Pin diameter	Pin length	Plate depth	Plate thickness	Ultimate tensile strength	Average tensile strength	Weight per meter
	p	d1 max	b1 min	d2 max	Lc max	h2 max	t/T max	Q min	Q0	q
	mm	mm	mm	mm	mm	mm	mm	kN/lbf	kN	kg/m
P129A1F1-P	129.0	90.0	29.0	24.9	86.0	60.0	8.0	350.0/78683	385.0	22.6

Donghua Chain No.	L1	G	F	W	h4	d4
	mm	mm	mm	mm	mm	mm
P129A1F1-P	66.0	90.0	110.0	146.0	30.0	M16